

# Feston

# USER MANUAL

## Hybrid Inverter

FES-5K-HB

FES-6K-HB

FES-8K-HB

FES-10K-HB

FES-12K-HB



# Contents

1. Safety Introductions -----	01 - 02
2. Product Introductions -----	02 - 06
2.1 Product Overview & Size	
2.2 Product Features	
2.3 Basic System Architecture	
3. Datasheet -----	06 - 07
4. Installation -----	08 - 32
4.1 Parts list	
4.2 Product handling requirements	
4.3 Mounting instructions	
4.4 Battery connection	
4.5 Grid connection and backup load connection	
4.6 PV Connection	
4.7 CT Connection	
4.7.1 Meter Connection	
4.8 Earth Connection(mandatory)	
4.9 WIFI Connection	
4.10 Wiring System for Inverter	
4.11 Wiring diagram	
4.12 Single phase parallel connection diagram	
4.13 Three phase parallel connection diagram	
5. Operation -----	33
5.1 Power ON/OFF	
5.2 Operation and Display Panel	
6. LCD Display Icons -----	34 - 51
6.1 Main Screen	
6.2 Detail page	
6.3 Curve Page-Solar & Load & Grid	
6.4 SETTINGS Menu	
6.5 Basic Setup Menu	
6.6 Grid Setup Menu	
6.7 Battery Setup Menu	
6.8 Li BMS Menu	
6.9 Fault Code Menu	
6.10 Aux Load Setup Menu	
6.11 System Mode Setup Menu	
6.12 Quick Control Setup Menu	
6.13 Advance Setup Menu	
7. Mode -----	52 - 53
8. Fault information and processing -----	53 - 56
9. Limitation of Liability -----	56
10. Appendix I -----	57 - 59
11. Appendix II -----	60

## About This Manual







The manual mainly describes the product information, guidelines for installation, operation and maintenance. The manual cannot include complete information about the photovoltaic (PV) system.

## How to Use This Manual

Read the manual and other related documents before performing any operation on the inverter. Documents must be stored carefully and be available at all times. Contents may be periodically updated or revised due to product development. The information in this manual is subject to change without notice.

## 1. Safety Introductions

### Labels description

Label	Description
	Caution, risk of electric shock symbol indicates important safety instructions, which if not correctly followed, could result in electric shock.
	The DC input terminals of the inverter must not be grounded.
	Surface high temperature, Please do not touch the inverter case.
	The AC and DC circuits must be disconnected separately, and the maintenance personnel must wait for 5 minutes before they are completely powered off before they can start working.
	CE mark of conformity
	Please read the instructions carefully before use.
	Symbol for the marking of electrical and electronics devices according to Directive 2002/96/EC. Indicates that the device, accessories and the packaging must not be disposed as unsorted municipal waste and must be collected separately at the end of the usage. Please follow Local Ordinances or Regulations for disposal or contact an authorized representative of the manufacturer for information concerning the decommissioning of equipment.

## Important Safety & Usage Guidelines:

- Before using the inverter, take a few minutes to read this manual. It contains essential safety and operating information you'll need now and in the future.
- Always check the battery's instructions and warning labels before connecting it to the inverter. Understanding your battery is just as important as understanding the inverter.
- Don't try to take the inverter apart. If something seems wrong, contact our service center. Tampering with the unit can lead to electric shock, fire, or permanent damage.
- Turning the inverter off is not enough—always disconnect all wiring before doing any maintenance or cleaning.
- Installing this inverter, especially with a battery, should only be done by trained and qualified personnel.
- Never try to charge a battery that's frozen. Let it thaw completely and inspect it before use.
- Make sure to use cables that match the specifications given in this manual. The wrong size can lead to overheating or performance issues.
- Be extra careful when using metal tools around batteries. Dropping one could cause a short circuit, spark, or even an explosion.
- Always refer to the Installation section of this manual before disconnecting any AC or DC terminals. Doing it the wrong way can be dangerous.
- This inverter must be connected to a grounded wiring system. Follow your local electrical codes to ensure a safe installation.
- Never allow the AC output and DC input to short circuit. Also, do not connect the inverter to mains power if the DC input is shorted.

## 2. Product Introductions

- This hybrid inverter combines inverter, solar charger, and battery charger functionalities into a single compact unit.
- It manages power flow intelligently between solar panels, utility grid, and battery storage to ensure continuous supply.
- A user-friendly LCD interface enables easy configuration of charging modes, input voltage range, and system priorities.
- Supports both off-grid and grid-tied system setups for flexible energy use across multiple applications. Ideal for residential homes, industries for backup power installations.

## 2.1 Product Overview

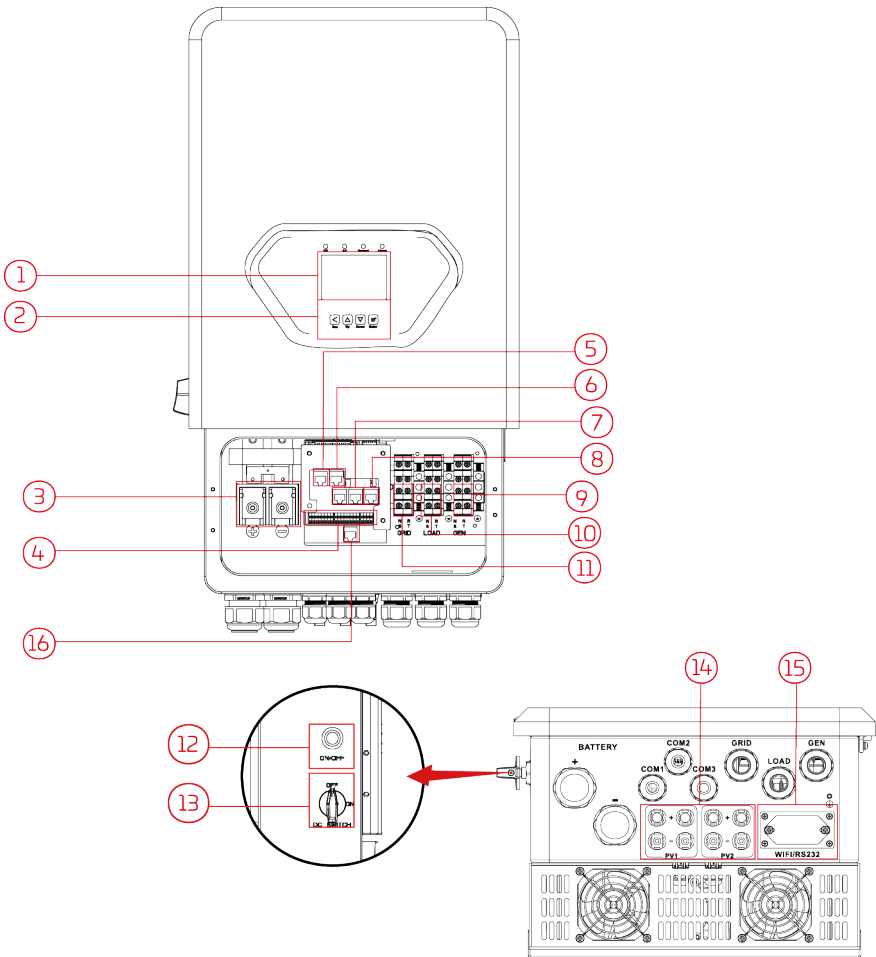

1: LCD display

2: Function buttons

3: Battery input connectors

4: Function port

5: BMS 485/CAN port

6: Modbus port

7: Parallel port

8: Meter-485 port

9: Generator input

10: Load

11: Grid

12: Power on/off button

13: DC switch

14: PV input

15: WiFi Interface

16: DRM port (optional)\*

\* Note: If you haven't selected DRM function when placing your order, the inverter you received will not have DRM port.

# Product Size

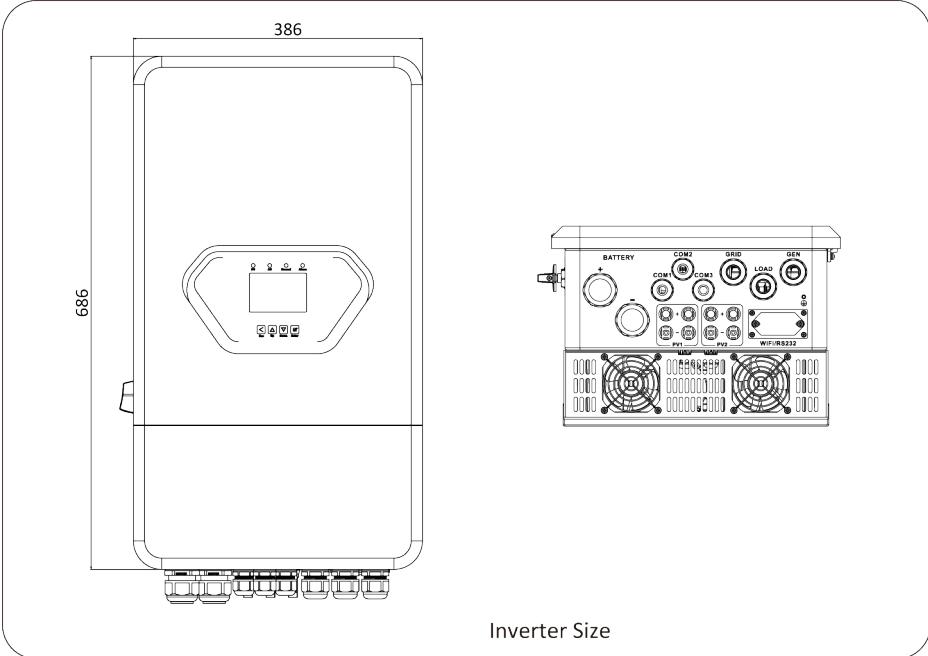

Inverter Size

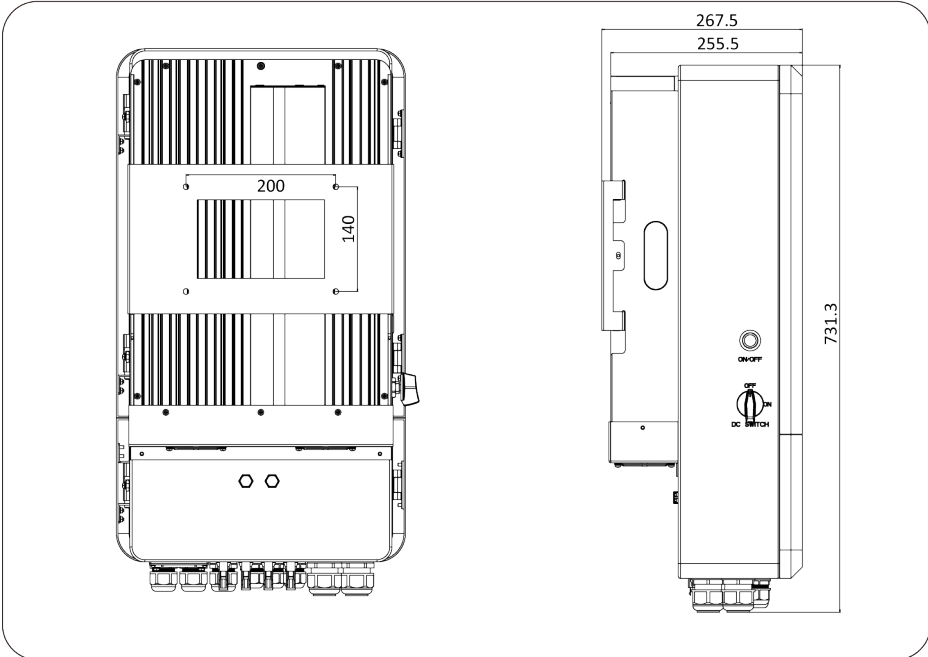

## 2.2 Product Features

- Supports both self-consumption and grid feed-in operation.
- Automatically restarts when AC power is restored.
- User-selectable supply priority: battery-first or grid-first.
- Operates in multiple modes: On-grid, Off-grid, and UPS.
- Battery charging current and voltage are configurable via LCD panel.
- Charging source priority whether AC, solar, or generator can be set through LCD.
- Compatible with mains power or generator input.
- Provides protection against overload, high temperature, and short circuit.
- Smart battery charging system with three-stage MPPT charging for battery health.
- Built-in dual MPPT trackers for enhanced solar input performance.
- Export limit function to prevent excess power from flowing into the grid.
- Supports Wi-Fi-based monitoring (optional or built-in).
- Time-of-use scheduling to control when energy is drawn or stored.
- Smart load functionality for managing connected devices efficiently.

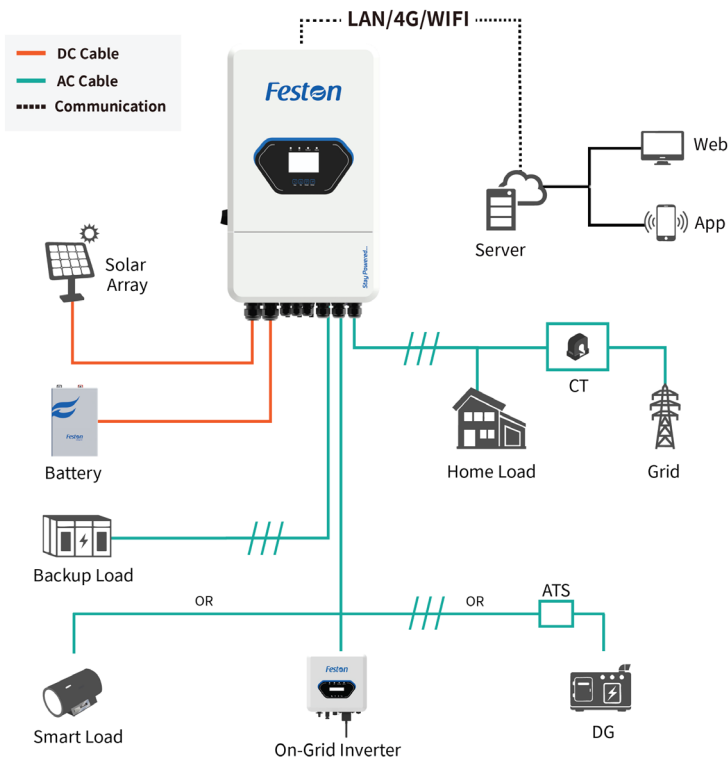

## 2.3 System Architecture

The following illustration shows a basic application of this inverter. It also includes the following devices to have a complete running system:

- **Generator or Utility**
- **PV modules**

Consult with your system integrator for other possible system architectures depending on your requirements.

This inverter can power all kinds of appliances in home or office environments, including motor-type appliances such as refrigerators and air conditioners.

## 3. Datasheet

<i>Model</i>	<i>FES-5K-HB</i>	<i>FES-6K-HB</i>	<i>FES-8K-HB</i>	<i>FES-10K-HB</i>	<i>FES-12K-HB</i>
<b>Battery Input Data</b>					
Battery Type	Lead-acid or Lithium-ion				
Battery Voltage Range(V)	40-60				
Max. Charging Current(A)	120	135	190	210	240
Max. Discharging Current(A)	120	135	190	210	240
Charging Strategy for Li-ion Battery	Self-adaption to BMS				
Number of Battery Input	1				
<b>PV String Input Data</b>					
Max. PV access power(W)	10000	12000	16000	20000	24000
Max. PV Input Power(W)	8000	9600	12800	16000	19200
Max. PV Input Voltage(V)	800				
Start-up Voltage(V)	160				
PV Input Voltage Range(V)	160-800				
MPPT Voltage Range(V)	200-650				
Full Load MPPT Voltage Range(V)	250-650		350-650		
Rated PV Input Voltage(V)	550				
Max. Operating PV Input Current(A)	20+20		26+26		
Max. Input Short-Circuit Current(A)	30+30		39+39		
No. of MPP Trackers/No. of Strings MPP Tracker	2/1+1		2/2+2		
<b>AC Input/Output Data</b>					
Rated AC Input/Output Active Power(W)	5000	6000	8000	10000	12000
Max. AC Input/Output Apparent Power(VA)	5500	6600	8800	11000	13200
Peak Power (off-grid)(W)	2 times of rated power, 10s				
Rated AC Input/Output Current(A)	7.6/7.3	9.1/8.7	12.2/11.6	15.2/14.5	18.2/17.4
Max. AC Input/Output Current(A)	8.4/8	10/9.6	13.4/12.8	16.7/16	20/19.2
Max. Continuous AC Passthrough (grid to load)(A)	45				
Max. Output Fault Current(A)	16.8	20	26.8	33.4	40
Max. Output Overcurrent Protection(A)	65				
Rated Input/Output Voltage/Range(V)	220/380V,230/400V 0.85Un-1.1Un				

Grid Connection Form	3L+N+PE
Rated Input/Output Grid Frequency/Range	50Hz/45Hz-55Hz 60Hz/55Hz-65Hz
Power Factor Adjustment Range	0.8 leading-0.8 lagging
Total Current Harmonic Distortion THDi	<3% (of nominal power)
DC Injection Current	<0.5%In
<b>Efficiency</b>	
Max. Efficiency	97.60%
Euro Efficiency	97.00%
MPPT Efficiency	>99%
<b>Equipment Protection</b>	
DC Polarity Reverse Connection Protection	Yes
AC Output Overcurrent Protection	Yes
AC Output Overvoltage Protection	Yes
AC Output Short Circuit Protection	Yes
Thermal Protection	Yes
DC Terminal Insulation Impedance Monitoring	Yes
DC Component Monitoring	Yes
Ground Fault Current Monitoring	Yes
Arc fault circuit interrupter (AFCI)	Optional
Power Network Monitoring	Yes
Island Protection Monitoring	Yes
Earth Fault Detection	Yes
DC Input Switch	Yes
Overvoltage Load Drop Protection	Yes
Residual Current (RCD) Detection	Yes
Surge Protection Level	TYPE II(DC), TYPE II(AC)
<b>Interface</b>	
Display	LCD+LED
Communication Interface	RS232, RS485, CAN
Monitor Mode	GPRS/WIFI/Bluetooth/4G/LAN(optional)
<b>General Data</b>	
Operating Temperature Range	-40 to +60 C , >45 C Derating
Permissible Ambient Humidity	0-100%
Permissible Altitude	3000m
Noise	≤ 55 dB
Ingress Protection(IP) Rating	IP 65
Inverter Topology	Non-Isolated
Over Voltage Category	OVC II(DC), OVC III(AC)
Cabinet size(W*H*D) [mm]	386W×686H×255.5D (Excluding connectors and brackets)
Weight(kg)	35.2
Warranty	Standard 5 years, extendable warranty
Type of Cooling	Intelligent Air Cooling
Grid Regulation	IEC 61727, IEC 62116, CEI 0-21, EN 50549, NRS 097, RD 140, UNE 217002, OVE-Richtlinie R25, G99, VDE-AR-N 4105
Safety EMC/Standard	IEC/EN 61000-6-1/2/3/4, IEC/EN 62109-1, IEC/EN 62109-2

## 4. Installation

### 4.1 Parts List

Check the equipment before installation. Please make sure nothing is damaged in the package. You should have received the items in the following package:

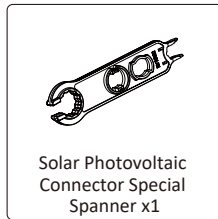
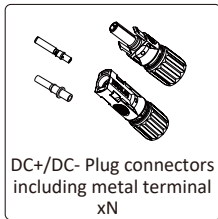
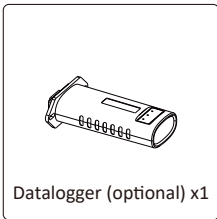
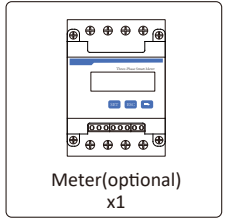
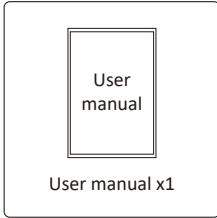
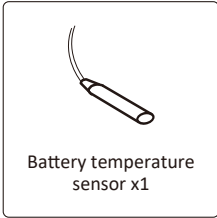
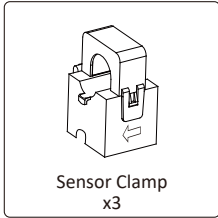
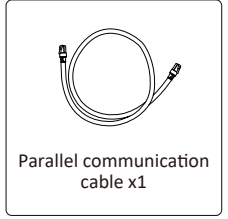
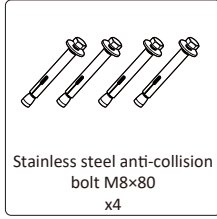
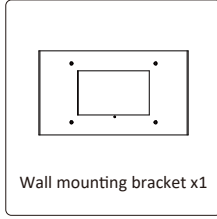
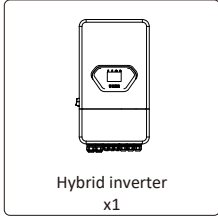

## 4.2 Product handling requirements

Lift the inverter out of the packing box and transport it to designated installation location.

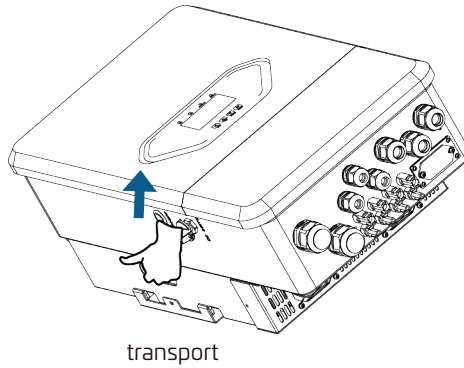

### CAUTION:

Improper handling may cause personal injury!

- Arrange an appropriate number of personnel to carry the inverter according to its weight, and installation personnel should wear protective equipment such as anti-impact shoes and gloves.
- Placing the inverter directly on a hard ground may cause damage to its metal enclosure. Protective materials such as sponge pad or foam cushion should be placed underneath the inverter.
- Move the inverter by one or two people or by using a proper transport tool.
- Move the inverter by holding the handles on it. Do not move the inverter by holding the terminals.

## 4.3 Mounting instructions

### Installation Precaution

This Hybrid inverter is designed for outdoor use(IP65), Please make sure the installation site meets below conditions:





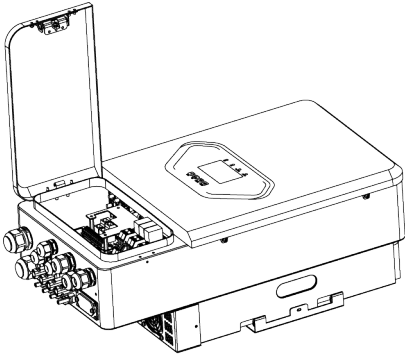





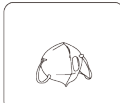

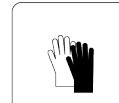

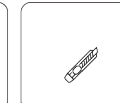
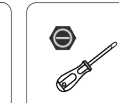
- Not in direct sunlight
- Not in areas where highly flammable materials are stored.
- Not in potential explosive areas.
- Not in the cool air directly.
- Not near the television Antenna or antenna cable.
- Not higher than altitude of about 3000 meters above sea level.
- Not in environment of precipitation or humidity(>95%)

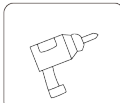
Please AVOID direct sunlight, rain exposure, snow laying up during installation and operation. Before connecting all wires, please take off the metal cover by removing screws as shown below:

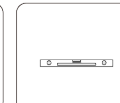
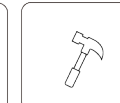
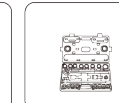
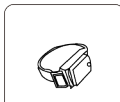
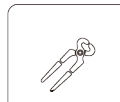

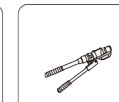
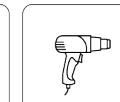
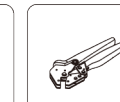
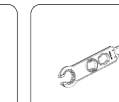
## Installations Tools

Installation tools can refer to the following recommended ones. Also, use other auxiliary tools on site.

						
Protective goggles	Anti-dust mask	Earplugs	Work gloves	Work shoes	Utility Knife	Slotted screwdriver
						
Cross screwdriver	Percussion drill	Pliers	Marker	Level	Rubber hammer	socket wrenches set
						
Anti-static wrist strap	Wire cutter	Wire stripper	Hydraulic pliers	Heat gun	Crimping tool4-6mm <sup>2</sup>	Solar connector wrench
						
Multimeter ≥1100 Vdc	RJ45 crimping plier	Cleaner				

## Considering the following points before selecting where to install:

- Please select a vertical wall with load-bearing capacity for installation, suitable for installation on concrete or other non-flammable surfaces, installation is shown below.
- Install this inverter at eye level in order to allow the LCD display to be read at all times.
- The ambient temperature is recommended to be between  $-40\sim 60^{\circ}\text{C}$  to ensure optimal operation.
- Be sure to keep other objects and surfaces as shown in the diagram to guarantee sufficient heat dissipation and have enough space for removing wires.

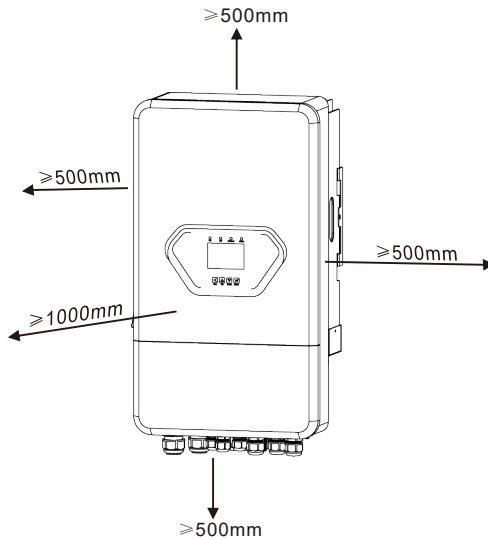

For proper air circulation to dissipate heat, allow a clearance of approx. 50cm to the side and approx. 50cm above and below the unit. And 100cm to the front.

## Mounting the inverter

Remember that this inverter is heavy! Please be careful when lifting out from the package. Choose the recommend drill head(as shown in below pic) to drill 4 holes on the wall, 82-90mm deep.

1. Use a proper hammer to fit the expansion bolt into the holes.
2. Carry the inverter and holding it, make sure the hanger aim at the expansion bolt, fix the inverter on the wall.
3. Fasten the screw head of the expansion bolt to finish the mounting.

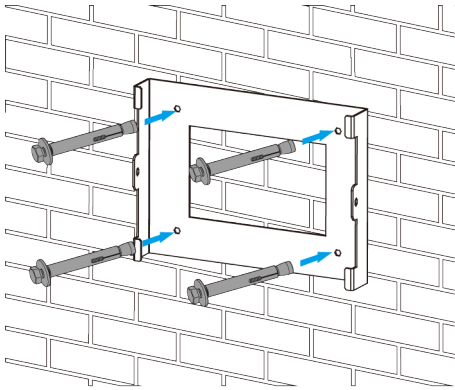

Inverter hanging plate installation

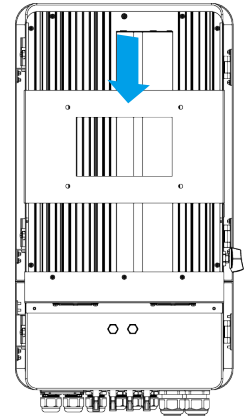

## 4.4 Battery connection

For safe operation and compliance, a separate DC over-current protector or disconnect device is required between the battery and the inverter. In some applications, switching devices may not be required but over-current protectors are still required. Refer to the typical amperage in the table below for the required fuse or circuit breaker size.

<i>Model</i>	<i>Cable(mm<sup>2</sup>)</i>	<i>Torque value(max)</i>
5/6kW	35	24.5Nm
8kW	50	24.5Nm
10/12kW	70	24.5Nm

Chart 4-1 Cable size



All wiring must be performed by a professional person.



Connecting the battery with a suitable cable is important for safe and efficient operation of the system. To reduce the risk of injury, refer to Chart 3-2 for recommended cables.

Please follow below steps to implement battery connection:

1. Please choose a suitable battery cable with correct connector which can well fit into the battery terminals.
2. Use a suitable screwdriver to unscrew the bolts and fit the battery connectors in, then fasten the bolt by the screwdriver, make sure the bolts are tightened with torque of 24.5 N.M in clockwise direction.
3. Make sure polarity at both the battery and inverter is correctly connected.

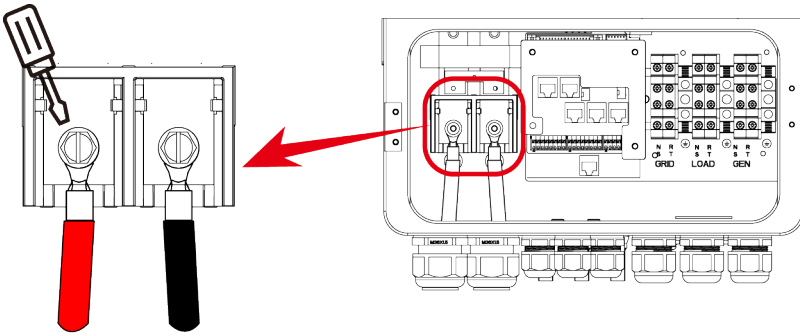

For 5-12kW model, battery connector screw size: M10

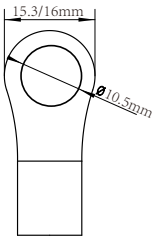

DC Battery Input

4. In case of children touch or insects go into the inverter, Please make sure the inverter connector is fasten to waterproof position by twist it clockwise.



Installation must be performed with care.



Before making the final DC connection or closing DC breaker/disconnect, be sure positive(+) must be connect to positive(+) and negative(-) must be connected to negative(-). Reverse polarity connection on battery will damage the inverter.

## Battery Box:

The battery box is designed to house and protect the battery bank used in the solar power system. It provides a safe enclosure to prevent physical damage, maintain stable operating conditions, and ensure secure electrical connections. The box helps in proper cable management and reduces risks from environmental factors such as dust, moisture, and accidental contact.

### GA DIAGRAM FOR BATTERY BOX

FRONT VIEW

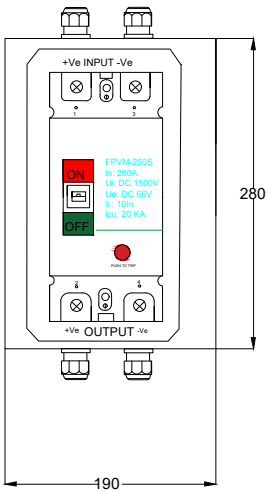

SIDE VIEW

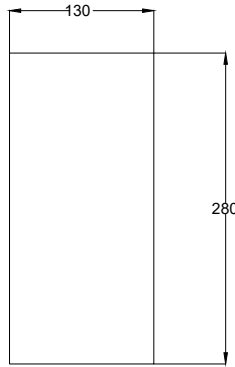

BOTTOM VIEW

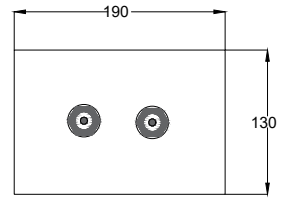

Battery Box			
SL.NO	DESCRIPTION	RATING	QTY
1	ENCLOSURE(PC)	190X280X130	1
2	DC MCCB	2POLE 250A, 66V	1
3	CABLE GLANDS	PG21	4

## Caution:

1. Ensure the battery box is well-ventilated to prevent heat buildup and gas accumulation.
2. Keep away from direct sunlight, rain, and flammable materials.
3. Always disconnect the battery terminals before performing any maintenance work.

## Points to remember for Installation:

1. Ensure the battery is placed securely at the installation location and correctly connected to the battery box, maintaining proper polarity. Even small polarity errors can lead to severe damage.
2. Connect the positive (+) terminal of the battery to the corresponding positive terminal of the inverter's battery input via the DCDB or tapped connection.
3. Connect the negative (-) terminal of the battery to the corresponding negative terminal of the inverter's battery input.
4. Tighten all terminals securely to avoid loose connections, and close the battery after completing the connections.

Model	Charging/Discharging Current (A)	Recommended Breaker Size (A)
5	120	160
6	135	200
8	190	250
10	210	315
12	240	315

# 4.4.1 Function port definition

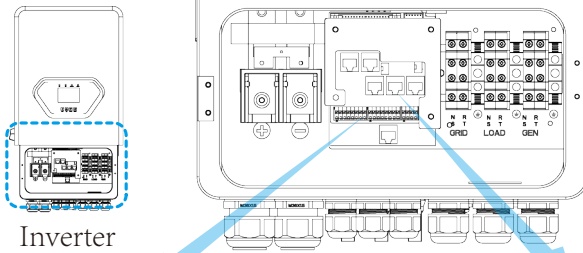

Inverter

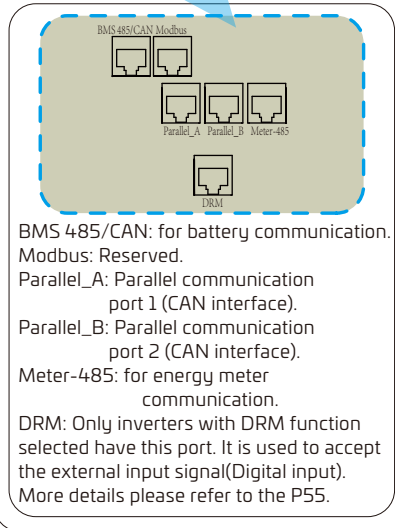
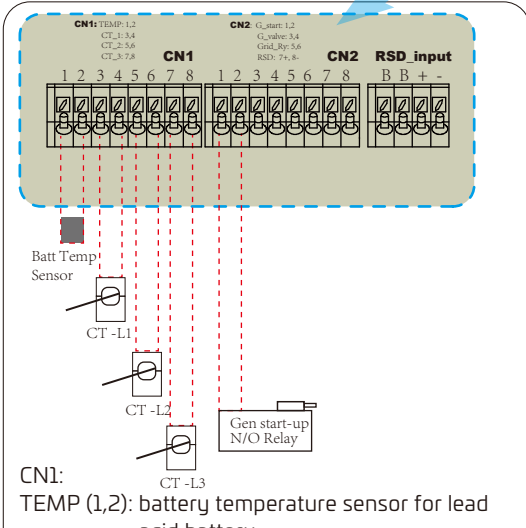

- CN1:**  
TEMP (1,2): battery temperature sensor for lead acid battery.
- CT\_1 (3,4): current transformer (CT1) for "zero export to CT" mode clamps on L1 when in three phase system.
- CT\_2 (5,6): current transformer (CT2) for "zero export to CT" mode clamps on L2 when in three phase system.
- CT\_3 (7,8): current transformer (CT3) for "zero export to CT" mode clamps on L3 when in three phase system.

- CN2:**  
G-start (1,2): dry contact signal for startup the diesel generator. When the "GEN signal" is active, the open contact (GS) will switch on (no voltage output).
- G-valve (3,4): Dry contact output. When the inverter is in off-grid mode and the "signal island mode" is checked, the dry contact will switch on.
- Grid\_Ry (5,6): reserved.
- RSD (7+,8-): When battery is connected and the inverter is in "ON" status, it will provide 12Vdc.
- RSD\_input (B,B,+,-): when the terminal "B" & "B" is short-circuited with additional wire connection, or there's 12Vdc input at the terminal "+ & - ", then the 12Vdc of RSD+ & RSD- will disappear immediately, and the inverter will shutdown immediately.

- BMS 485/CAN Modbus: for battery communication.
- Modbus: Reserved.
- Parallel\_A: Parallel communication port 1 (CAN interface).
- Parallel\_B: Parallel communication port 2 (CAN interface).
- Meter-485: for energy meter communication.
- DRM: Only inverters with DRM function selected have this port. It is used to accept the external input signal(Digital input). More details please refer to the P55.

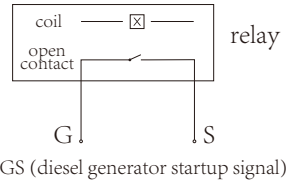

## 4.4.2 Temperature sensor connection for lead-acid battery

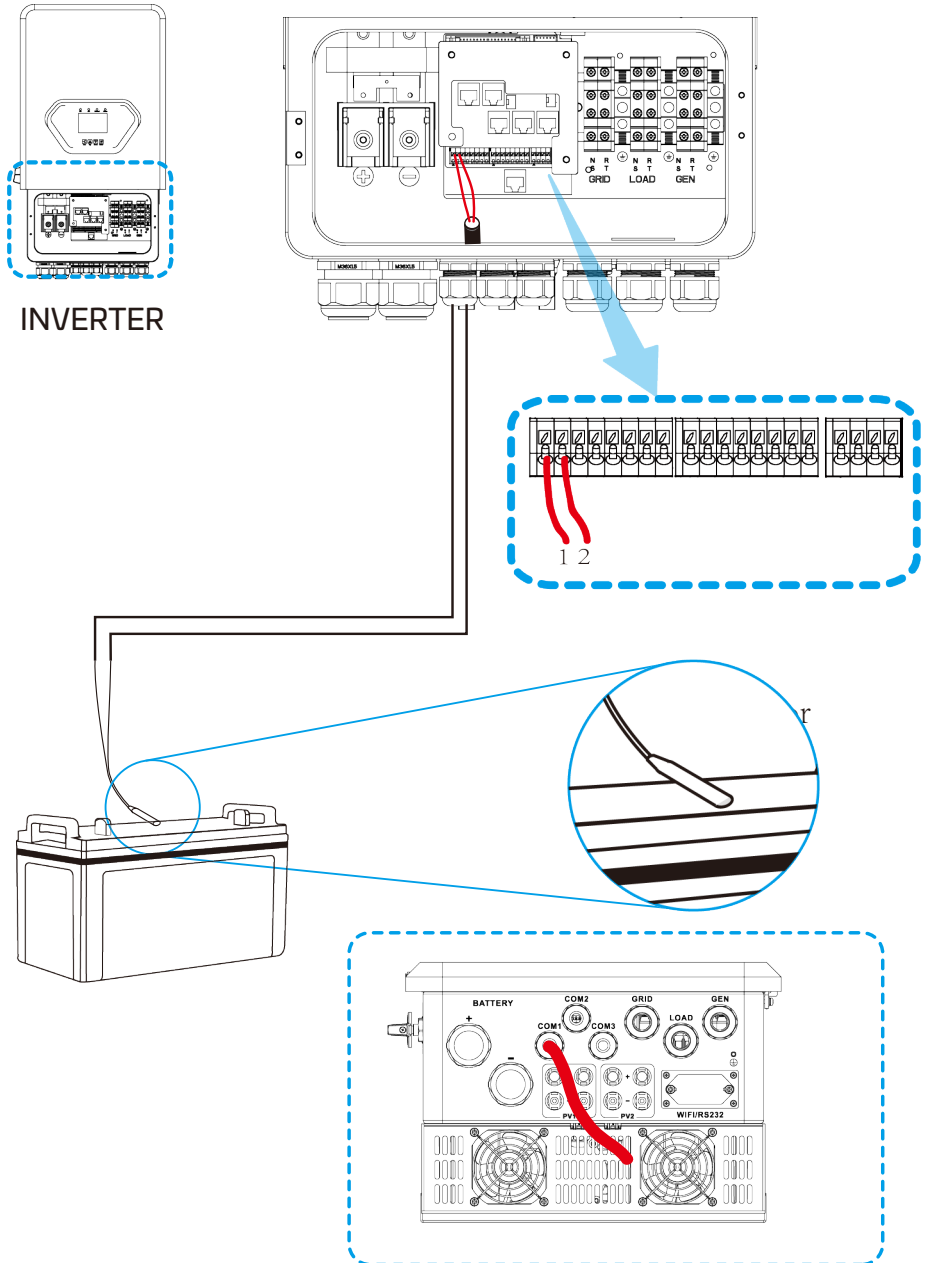

## 4.5 Grid connection and backup load connection

- Before connecting to the grid, a separate AC breaker must be installed between the inverter and the grid, and also between the backup load and the inverter. This will ensure the inverter can be securely disconnected during maintenance and fully protected from over current. The recommended of AC breaker for the load port is 63A for 5/6/8/10/12kW. The recommended of AC breaker for the grid port is 63A for 5/6/8/10/12kW.
- There are three terminal blocks with "Grid" "Load" and "GEN" markings. Please do not misconnect input and output connectors.



### Note:

In final installation, breaker certified according to IEC 60947-1 and IEC 60947-2 shall be installed with the equipment.

All wiring must be performed by a qualified personnel. It is very important for system safety and efficient operation to use appropriate cable for AC input connection. To reduce risk of injury, please use the proper recommended cable as below.

Grid connection and backup load connection (Copper wires)

Model	Wire Size	Cable(mm <sup>2</sup> )	Torque value(max)
5/6kW	12AWG	2.5	1.2Nm
8kW	10AWG	4.0	1.2Nm
10/12kW	8AWG	6.0	1.2Nm

Grid connection and backup load connection (Copper wires) (bypass)

Model	Wire Size	Cable(mm <sup>2</sup> )	Torque value(max)
5/6/8/10/12kW	6AWG	10	1.2Nm

Chart 4-2 Recommended Size for AC wires

Please follow below steps to implement Grid, load and Gen port connection:

1. Before making Grid, load and Gen port connection, be sure to turn off AC breaker or disconnecter first.
2. Remove insulation sleeve 10mm length, unscrew the bolts, insert the wires according to polarities indicated on the terminal block and tighten the terminal screws. Make sure the connection is complete.

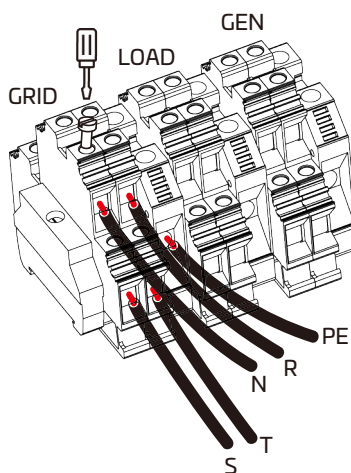
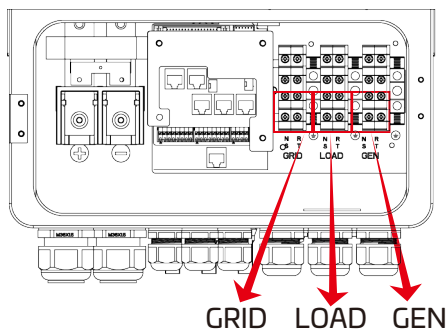

Be sure that AC power source is disconnected before attempting to wire it to the unit.

3. Then, insert AC output wires according to polarities indicated on the terminal block and tighten terminal. Be sure to connect corresponding N wires and PE wires to related terminals as well.
4. Make sure the wires are securely connected.
5. Appliances such as air conditioner are required at least 2-3 minutes to restart because it is required to have enough time to balance refrigerant gas inside of circuit. If a power shortage occurs and recovers in short time, it will cause damage to your connected appliances. To prevent this kind of damage, please check manufacturer of air conditioner if it is equipped with time-delay function before installation. Otherwise, this inverter will trigger overload fault and cut off output to protect your appliance but sometimes it still causes internal damage to the air conditioner

## ACDB(AC Distribution Box) Installation Instructions:

The AC Distribution Box (ACDB) is used to safely route and protect the AC output from the solar inverter before it is supplied to the load or the utility grid. It houses protective devices such as MCBs, MCCBs, and surge protection devices to safeguard the system from overloads, short circuits, and voltage surges. The ACDB ensures controlled distribution of AC power and provides isolation for maintenance activities.

### GA DIAGRAM FOR ACDB

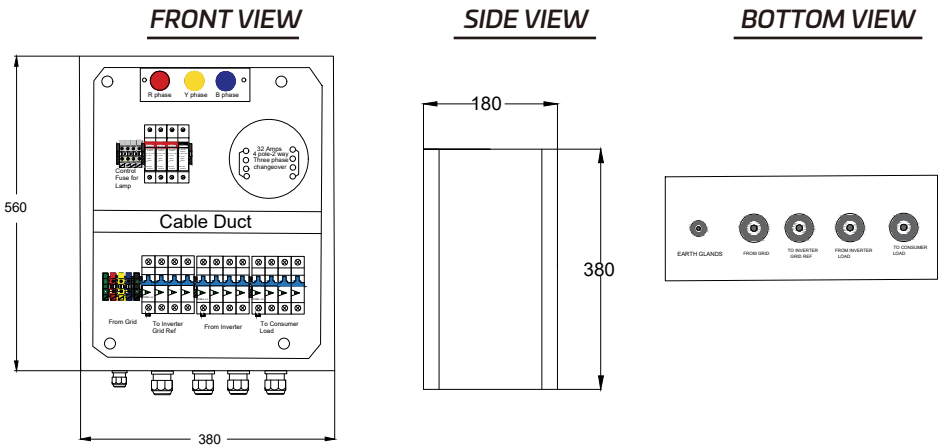

### Caution

1. Ensure the ACDB is installed in such a way that it complies with the specified IP rating.
2. Do not work on the ACDB while the system is ON. Disconnect the inverter and grid supply before start of the installation.
3. Only qualified personnel should perform installation or maintenance.

### Points to remember for Installation

1. Mount the ACDB securely on a wall or a strong surface at a convenient operating height.
2. Connect the AC output from the inverter to the **input terminals** of the ACDB using appropriately rated cables.
3. Connect the **output terminals** of the ACDB to the load or utility grid connection point.
4. Ensure proper grounding of the ACDB for safety.
5. Verify that all breakers and protection devices inside the ACDB are correctly rated and firmly secured before switching ON

## 4.6 PV Connection

Before connecting to PV modules, please install a separately DC circuit breaker between inverter and PV modules. It is very important for system safety and efficient operation to use appropriate cable for PV module connection. To reduce risk of injury, please use the proper recommended cable size as below.

<i>Model</i>	<i>Wire Size</i>	<i>Cable(mm<sup>2</sup>)</i>
5/6/8/10/12kW	10AWG	4

Chart 4-3 Cable size



To avoid any malfunction, do not connect any PV modules with possible current leakage to the inverter. For example, grounded PV modules will cause current leakage to the inverter. When using PV modules, please ensure the PV+ & PV- of solar panel is not connected to the system ground bar.



It is requested to use PV junction box with surge protection. Otherwise, it will cause damage on inverter when lightning occurs on PV modules.

### 4.6.1 PV Module Selection:

When selecting proper PV modules, please be sure to consider below parameters:

- 1) Open circuit Voltage (Voc) of PV modules not exceeds max. PV array open circuit voltage of inverter.
- 2) Open circuit Voltage (Voc) of PV modules should be higher than min. start voltage.
- 3) The PV modules used to connected to this inverter shall be Class A rating certified according to IEC 61730.

<i>Inverter Model</i>	<i>5kW</i>	<i>6kW</i>	<i>8kW</i>	<i>10kW</i>	<i>12kW</i>
PV Input Voltage	550V (160V-800V)				
PV Array MPPT Voltage Range	200V-650V				
No. of MPP Trackers	2				
No. of Strings per MPP Tracker	1+1			2+2	

Chart 4-4

## 4.6.2 PV Module Wire Connection:

1. Switch the Grid Supply Main Switch(AC)OFF.
2. Switch the DC Isolator OFF.
3. Assemble PV input connector to the inverter.



### *Safety Hint:*

When using PV modules, please ensure the PV+ & PV- of solar panel is not connected to the system ground bar.



### *Safety Hint:*

Before connection, please make sure the polarity of the output voltage of PV array matches the “DC+” and “DC-” symbols.



### *Safety Hint:*

Before connecting inverter, please make sure the PV array open circuit voltage is within the 800V of the inverter.

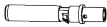
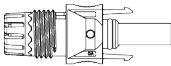

Pic 4.1 DC+ male connector

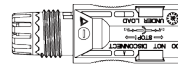

Pic 4.2 DC- female connector



### *Safety Hint:*

Please use approved DC cable for PV system.

The steps to assemble the DC connectors are listed as follows:

- a) Strip off the DC wire about 7mm, disassemble the connector cap nut ( see picture 4.3).

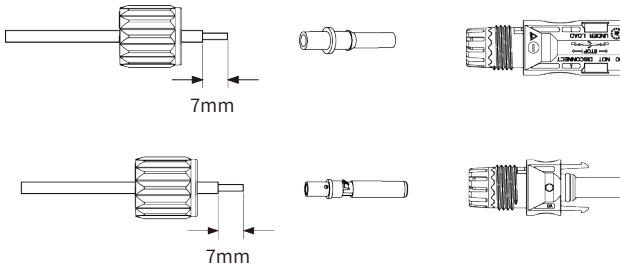

Pic 4.3 Disassemble the connector cap nut

b) Crimping metal terminals with crimping pliers as shown in picture 4.4.

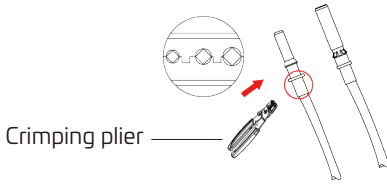

Pic 4.4 Crimp the contact pin to the wire

c) Insert the contact pin to the top part of the connector and screw up the cap nut to the top part of the connector. (as shown in picture 4.5).

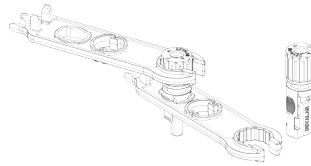

Pic 4.5 connector with cap nut screwed on

d) Finally insert the DC connector into the positive and negative input of the inverter, shown as picture 4.6.

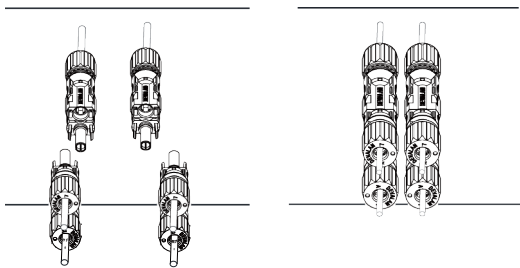

Pic 4.6 DC input connection



**Warning:**

Sunlight shines on the panel will generate voltage, high voltage in series may cause danger to life. Therefore, before connecting the DC input line, the solar panel needs to be blocked by the opaque material and the DC switch should be 'OFF', otherwise, the high voltage of the inverter may lead to life-threatening conditions.



**Warning:**

Please use its own DC power connector from the inverter accessories. Do not interconnect the connectors of different manufacturers.

## DCDB(DC Distribution Box) Installation Instructions:

The DC distribution box is used to combine and control the DC output from the solar panels before it enters the inverter. It has protection devices such as DC circuit breakers, fuses, and surge protection units, ensuring safe operation, fault isolation, and protection of the inverter from overcurrent and voltage surges.

### Caution

1. Ensure the DCDB is installed in such a way that it complies with the specified IP rating.
2. Always switch off the inverter before performing maintenance or inspection.
3. Verify correct polarity connections from the solar panels to prevent damage to internal components.

**NOTE:** Ensure the PV panels are disconnected or covered before starting work to avoid live DC voltage.

### GA DIAGRAM FOR DCDB

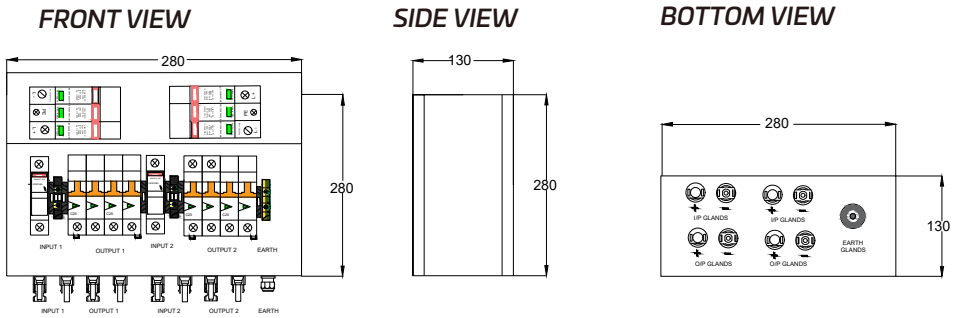

### Points to remember for Installation:

1. Identify the positive and negative output cables from the solar combiner box.
2. Use the recommended DC cable size as per inverter specifications.
3. Connect the positive wire from the combiner box to the DC MCB or fuse inside the DCDB.
4. Connect the negative wire from the combiner box to the negative busbar in the DCDB.
5. Ensure the DC SPD is connected between the positive and negative terminals inside the DCDB.
6. From the DCDB output terminals, connect the positive and negative cables to the DC input terminals of the inverter.
7. Check all terminals for firm and secure connections, avoiding loose wiring.
8. Close DCDB securely before turning ON the system.

## 4.7 CT Connection

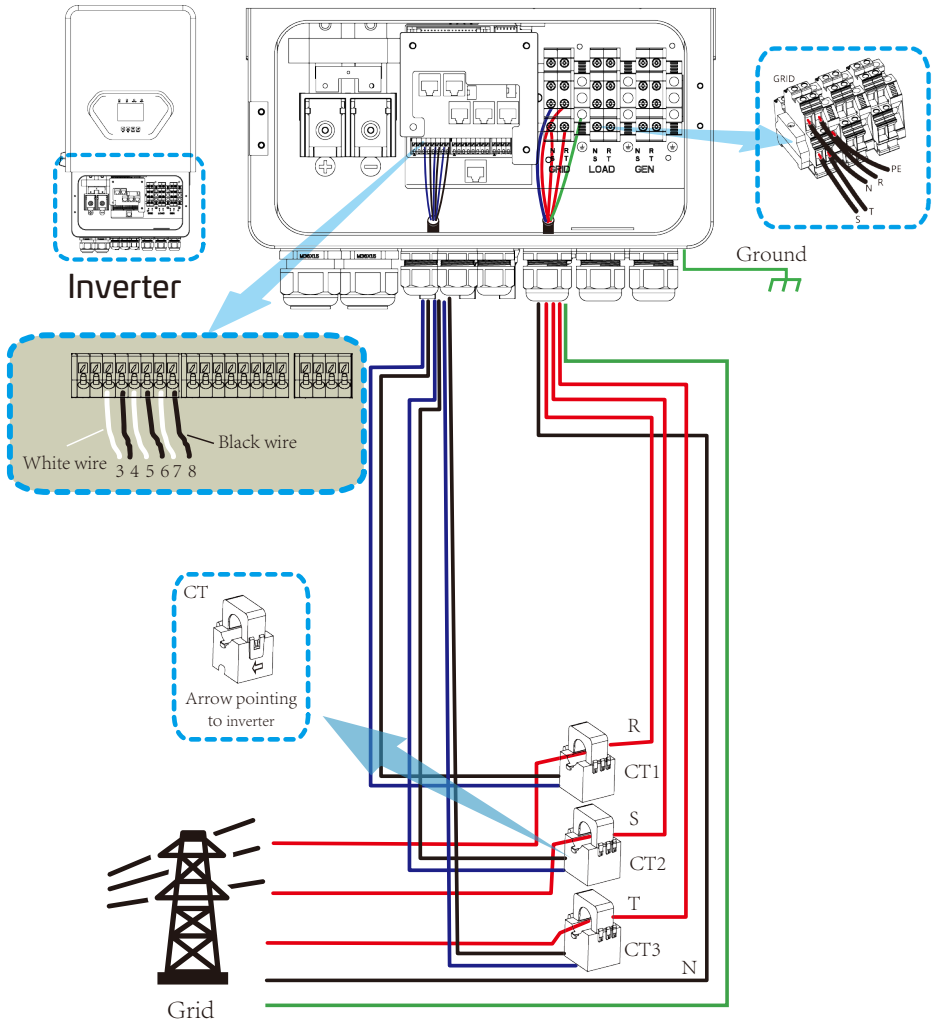

\*Note: when the reading of the load power on the LCD is not correct, please reverse the CT arrow.

# 4.7.1 Meter Connection

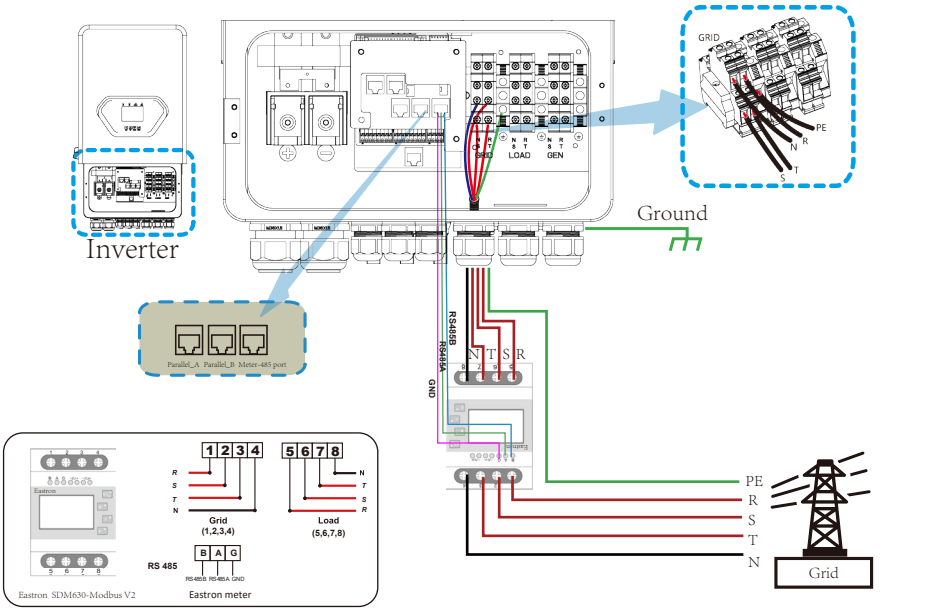
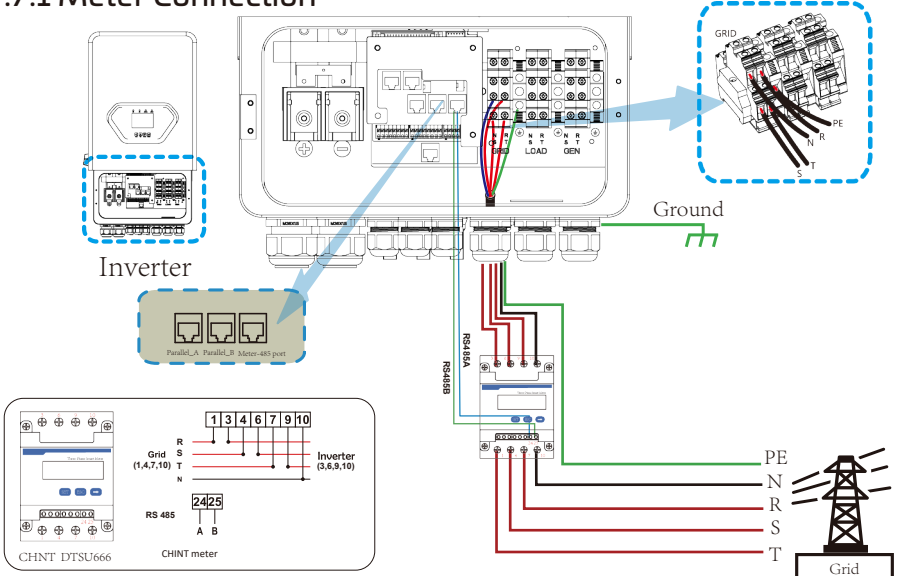

**Note:**

When the inverter is in the off-grid state, the N line needs to be connected to the earth.

## 4.8 Earth Connection(mandatory)

Ground cable shall be connected to ground plate on grid side, this prevents electric shock if the original protective conductor fails.

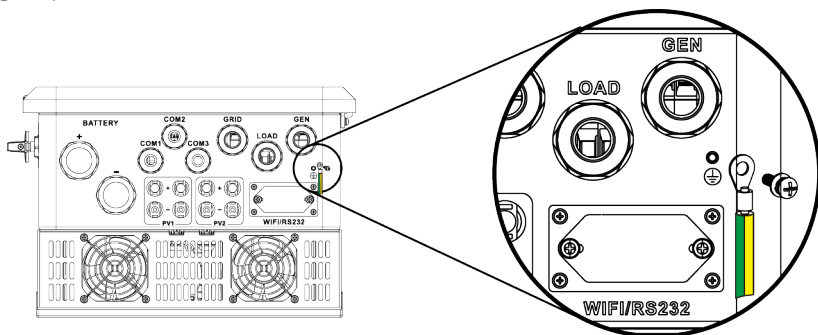

Earth connection (Copper wires)

Model	Wire Size	Cable(mm <sup>2</sup> )	Torque value(max)
5/6kW	12AWG	2.5	1.2Nm
8kW	10AWG	4.0	1.2Nm
10/12kW	8AWG	6.0	1.2Nm

Earth connection (Copper wires) (bypass)

Model	Wire Size	Cable(mm <sup>2</sup> )	Torque value(max)
5/6/8/10/12kW	6AWG	10	1.2Nm



### Warning:

Inverter has built-in leakage current detection circuit, The type A RCD can be connected to the inverter for protection according to the local laws and regulations. If an external leakage current protection device is connected, its operating current must be equal to 300 mA or higher, otherwise inverter may not work properly.

## 4.9 WIFI Connection

For the configuration of Wi-Fi Plug, please refer to illustrations of the Wi-Fi Plug. The Wi-Fi Plug is not a standard configuration, it's optional.

## 4.10 Wiring System for Inverter

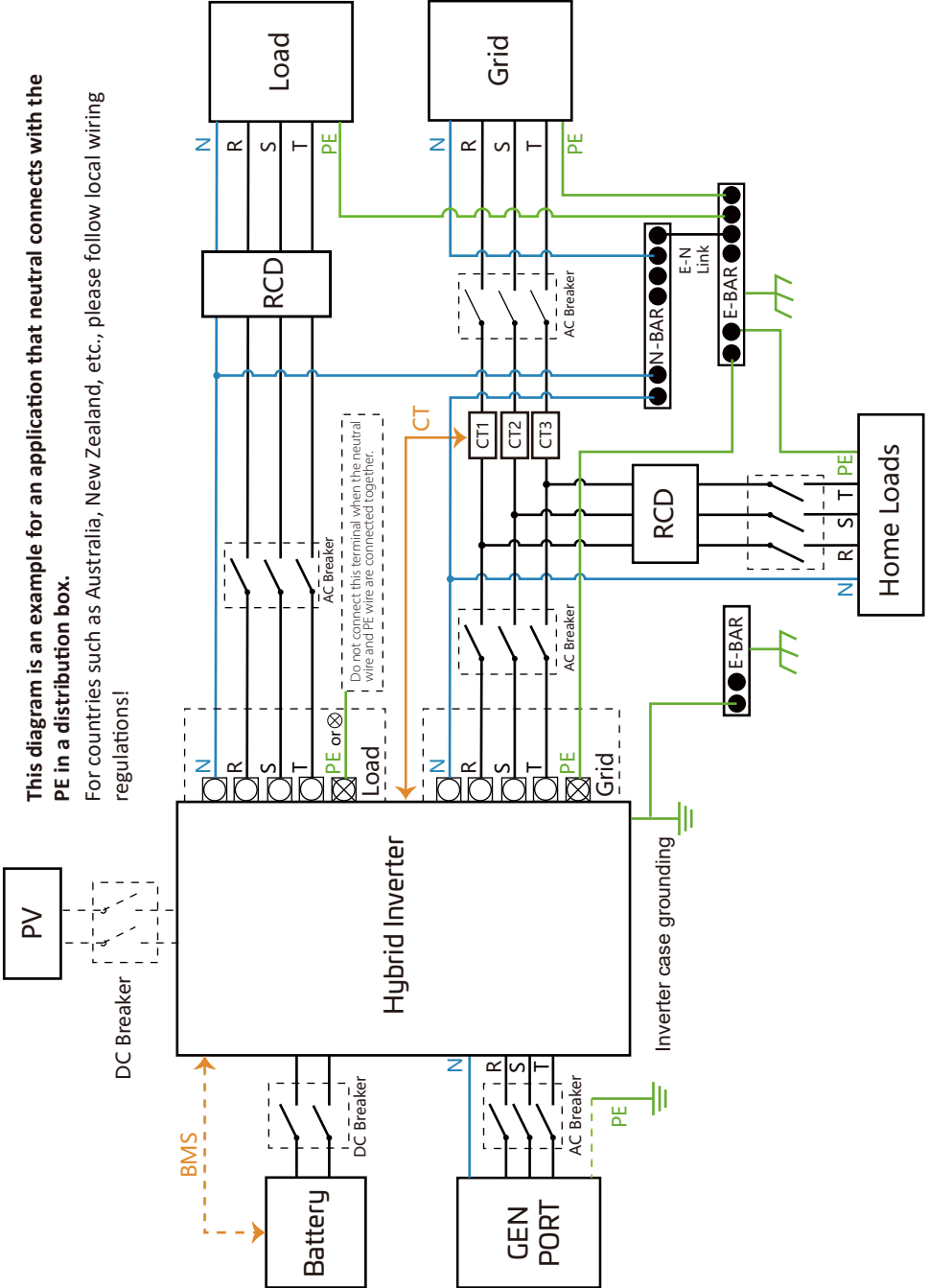



— CAN — Lwire — N wire — PE wire

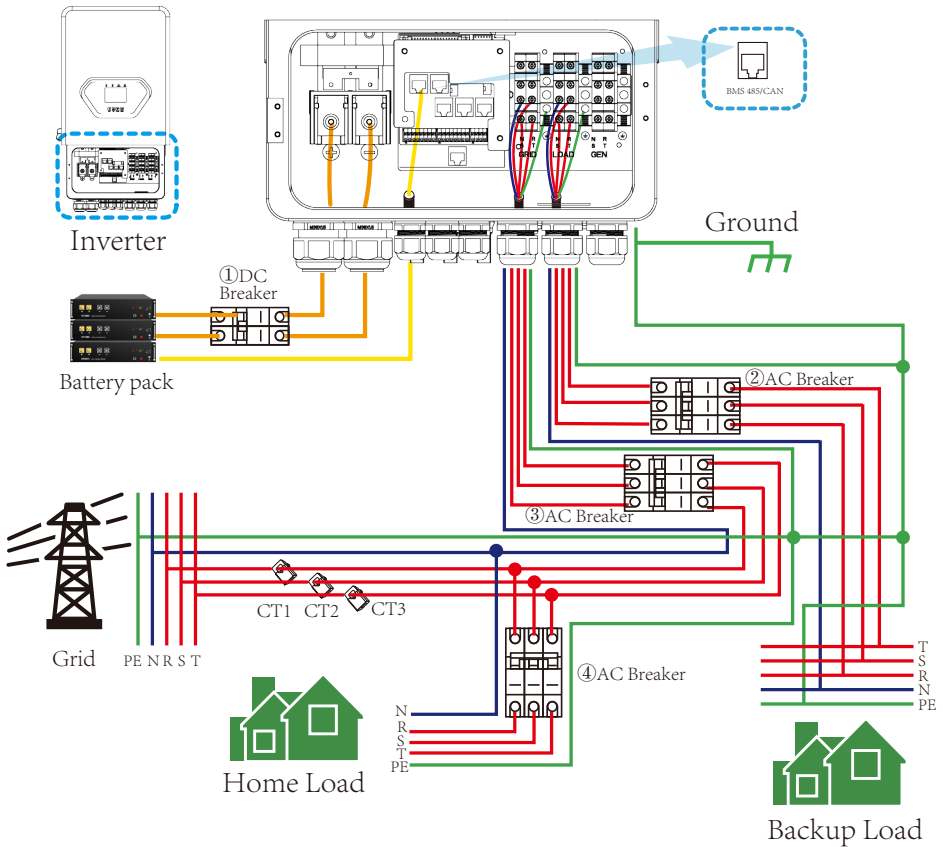

① DC Breaker for battery  
 FES-5K-HB: 150A DC breaker  
 FES-6K-HB: 200A DC breaker  
 FES-8K-HB: 250A DC breaker  
 FES-10K-HB: 300A DC breaker  
 FES-12K-HB: 300A DC breaker

② AC Breaker for backup load  
 FES-5K-HB-EU: 63A AC breaker  
 FES-6K-HB: 63A AC breaker  
 FES-8K-HB: 63A AC breaker  
 FES-10K-HB: 63A AC breaker  
 FES-12K-HB: 63A AC breaker

③ AC Breaker for grid  
 FES-5K-HB-EU: 63A AC breaker  
 FES-6K-HB: 63A AC breaker  
 FES-8K-HB: 63A AC breaker  
 FES-10K-HB: 63A AC breaker  
 FES-12K-HB: 63A AC breaker

④ AC Breaker for home load  
 Depends on household loads

## 4.12 Typical application diagram of diesel generator

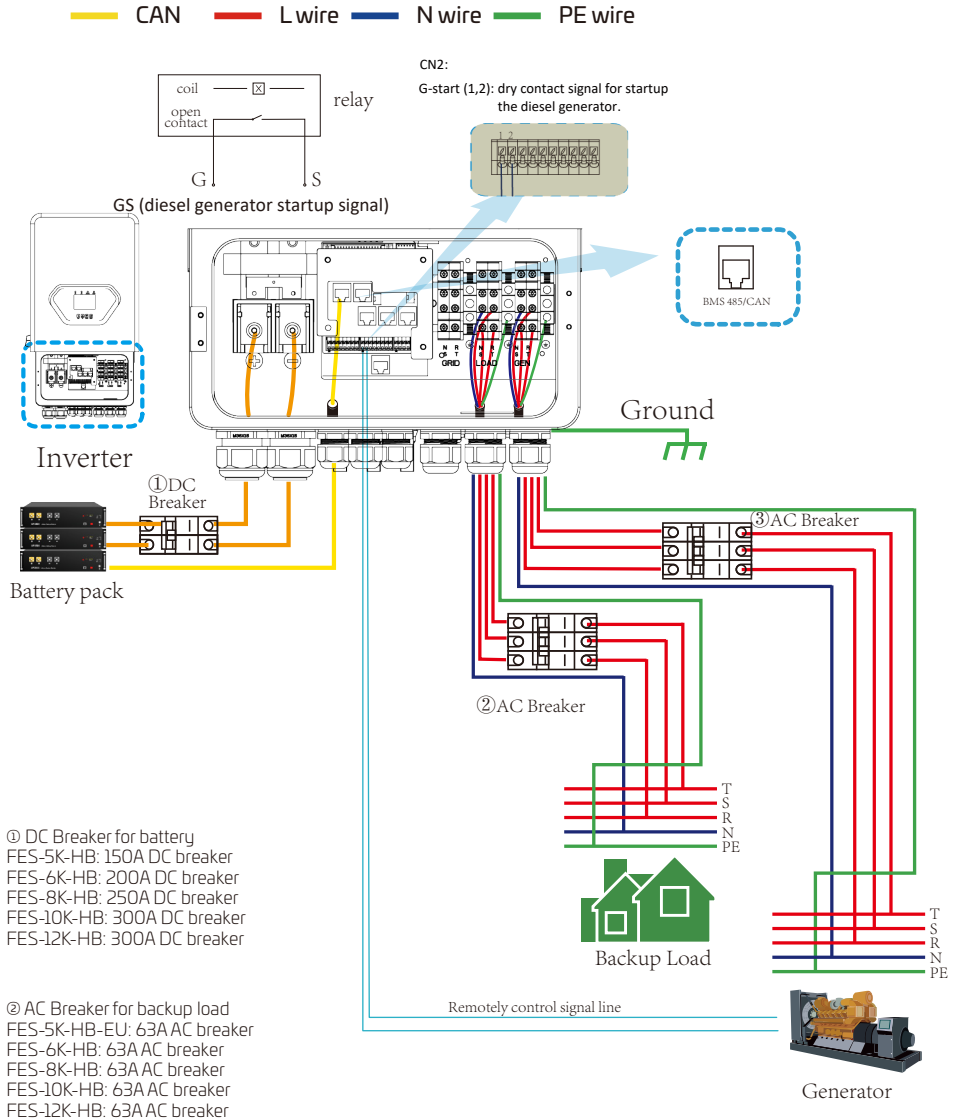

① DC Breaker for battery  
 FES-5K-HB: 150A DC breaker  
 FES-6K-HB: 200A DC breaker  
 FES-8K-HB: 250A DC breaker  
 FES-10K-HB: 300A DC breaker  
 FES-12K-HB: 300A DC breaker

② AC Breaker for backup load  
 FES-5K-HB-EU: 63A AC breaker  
 FES-6K-HB: 63A AC breaker  
 FES-8K-HB: 63A AC breaker  
 FES-10K-HB: 63A AC breaker  
 FES-12K-HB: 63A AC breaker

③ AC Breaker for generator  
 FES-5K-HB-EU: 63A AC breaker  
 FES-6K-HB: 63A AC breaker  
 FES-8K-HB: 63A AC breaker  
 FES-10K-HB: 63A AC breaker  
 FES-12K-HB: 63A AC breaker

# 4.13 Three phase parallel connection diagram

Note: For the parallel system, please choose the "Limit to Grid + Load" mode.

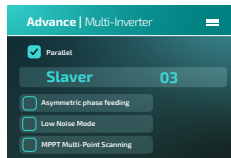
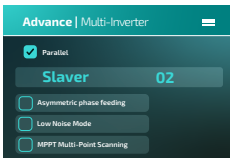
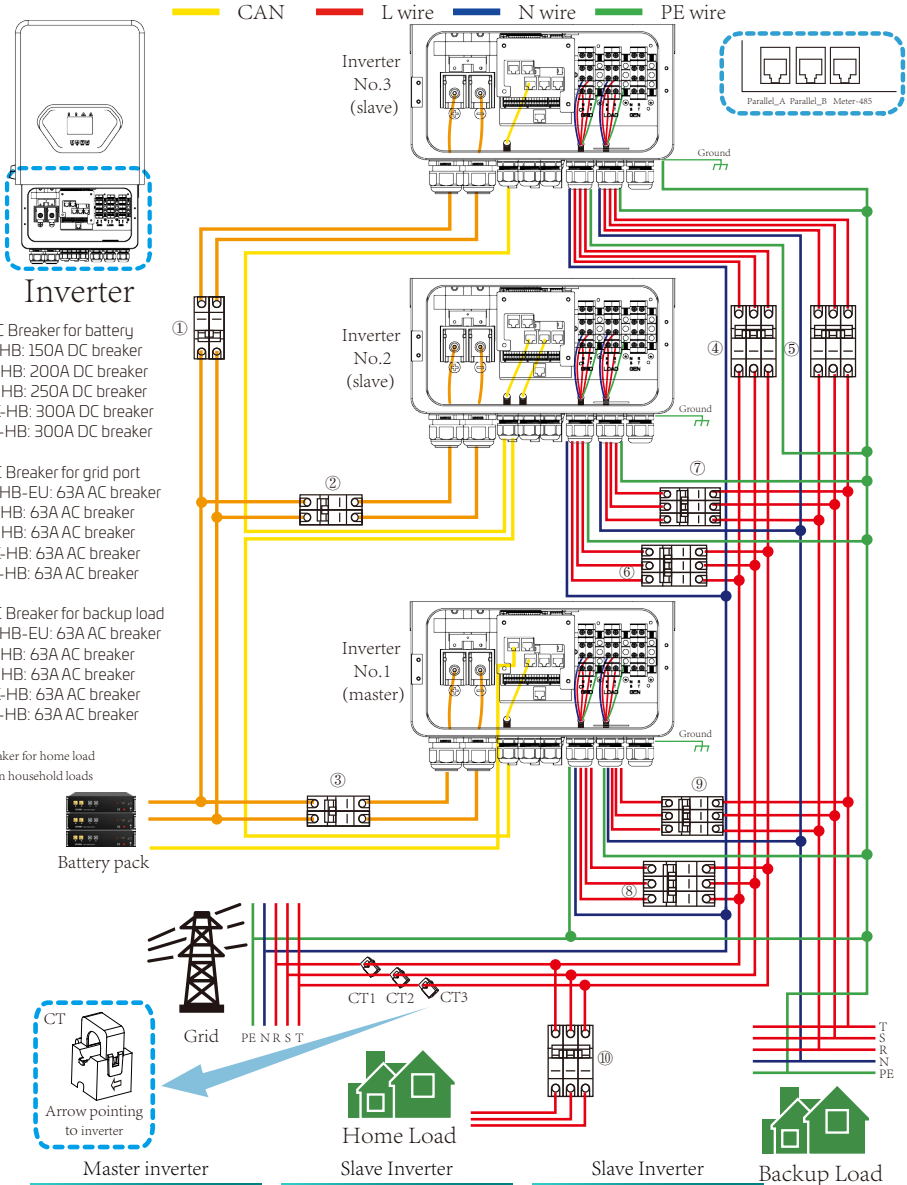

# 5. OPERATION

## 5.1 Power ON/OFF

Once the unit has been properly installed and the batteries are connected well, simply press On/Off button(located on the left side of the case) to turn on the unit. When system without battery connected, but connect with either PV or grid, and ON/OFF button is switched off, LCD will still light up(Display will show OFF), In this condition, when switch on ON/OFF button and select NO battery,system can still working.

## 5.2 Operation and Display Panel

The operation and display panel, shown in below chart, is on the front panel of the inverter. It includes four function keys and a LCD display, indicating the operating status and input/output power information.

<i>Function Key</i>	<i>Description</i>
Esc	To exit setting mode
Up	To go to previous selection
Down	To go to next selection
Enter	To confirm the selection

Chart 5-1 Function Buttons

## 6. LCD Display Icons

### 6.1 Main Screen

The LCD is touchscreen, below screen shows the overall information of the inverter.

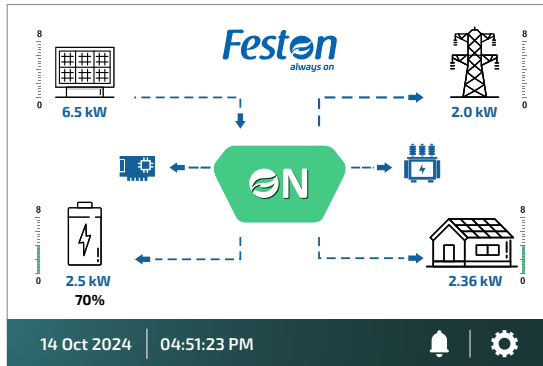

1. The icon in the center of the home screen indicates that the system is Normal operation. If it turns into "comm./FXX" , it means the inverter has communication errors or other errors, the error message will display under this icon(FXX errors, detail error info can be viewed in the System Alarms menu).

2. At the bottom of the screen is the time.

3. SETTINGS Icon(Gear icon in the lower right corner), Press this set button, you can enter into the system setup screen which including Basic Setup, Grid Setup, Battery Setup, Li BMS, Fault Code, Aux Load, System Mode, Smart Link, Quick Control and Advance.

4. The main screen showing the info including Solar, Grid, Battery, Load, Generator and On-Grid Inverter.

- PV power and Load power always keep positive.
- Negative grid power means selling power to the grid, while positive means taking power from the grid.
- Negative battery power means charging, while positive battery power means discharging.

### 6.1.1 LCD operation flow chart

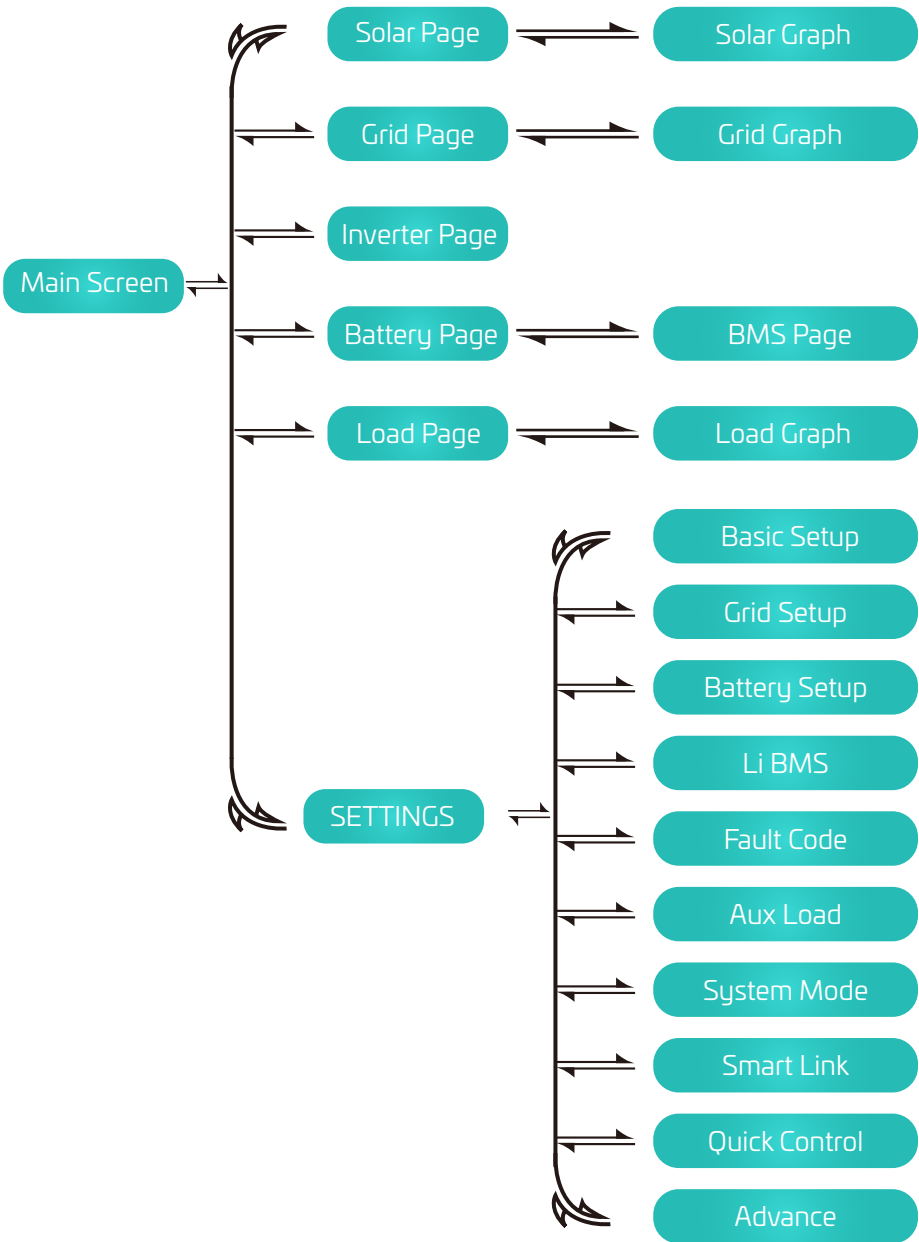

# 6.2 Detail page

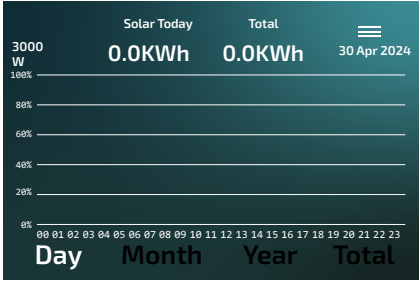

This is Solar Panel detail page.

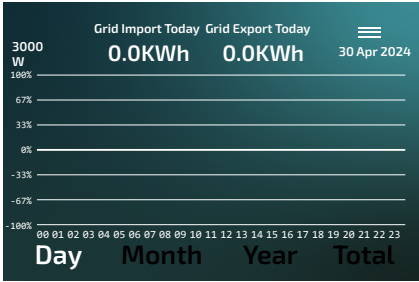

This is Grid detail page.

**INFO**      ☰

Comm:                      MCU:  
ARC:                        BMS:

This is Inverter detail page.

<p><b>Load Power</b></p> <p>OW</p> <p>OV    OW OV    OW OV    OW</p>	<p><b>Grid Power</b></p> <p>OW 0.0Hz</p> <p>OV    0.0A OV    0.0A OV    0.0A</p>	<p><b>PV</b></p> <p>DC_P1: OW V1: OV I1: 0.0A DC_P2: OW V2: OV I2: 0.0A</p>
<p><b>Inverter Power</b></p> <p>OW 0.0 Hz</p> <p>OV    0.0A OV    0.0A OV    0.0A</p> <p>INV_P OW OW    AC_T OW    100.0 C</p>	<p>HM:    LD: OW    OW OW    OW OW    OW</p>	<p><b>Battery</b></p> <p>OW V: 0.00V I: 0.00A T: 0.0 C</p>

This is Inverter detail page.

AC\_T: mean Heat-sink temperature.

## 6.3 Curve Page-Solar & Load & Grid

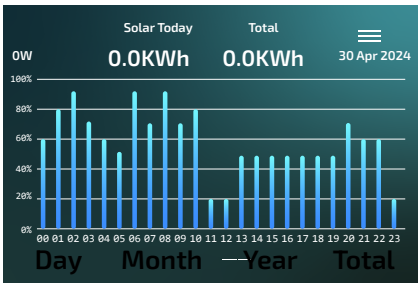
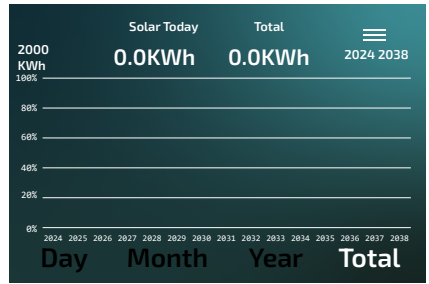
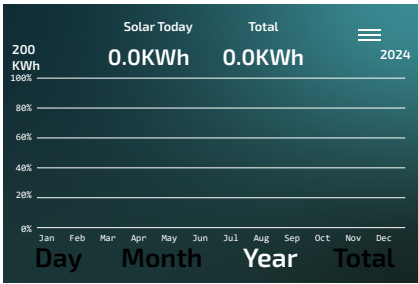
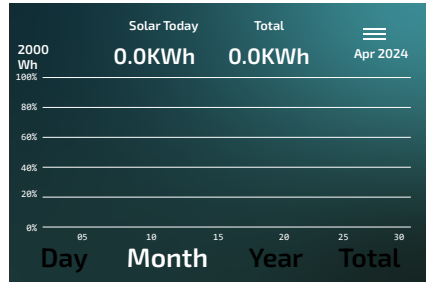
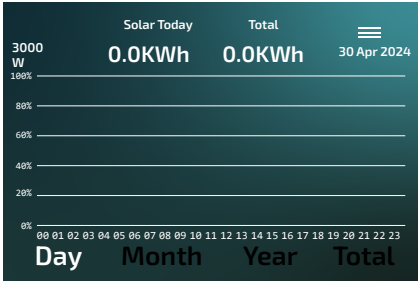

Solar power curve for daily, monthly, yearly and total can be roughly checked on the LCD, for more accuracy power generation, please check on the monitoring system. Click the buttons below the LCD screen to view the power curves of different time periods. The operation of checking the grid power and load power is similar to the above operation.

## 6.4 SETTINGS Menu

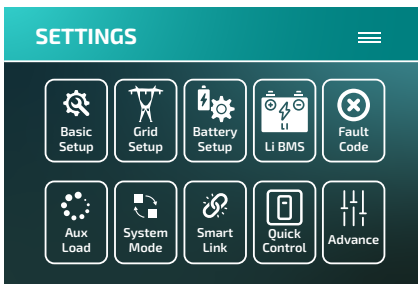

This is SETTINGS Menu page.

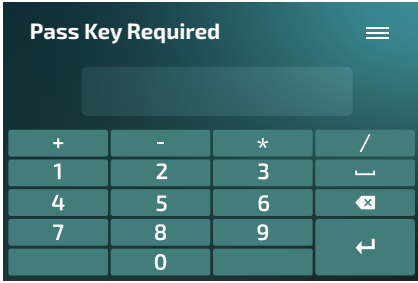

To avoid arbitrary changes or misoperation of key parameters, a preset password needs to be entered before making changes. The preset password is 7777.

## 6.5 Basic Setup Menu

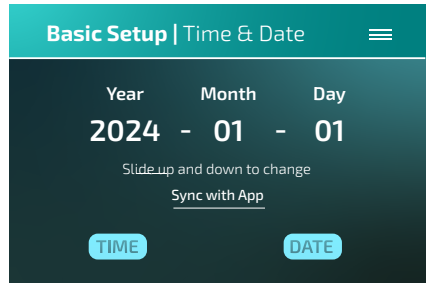
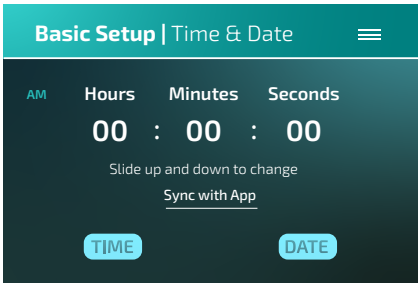
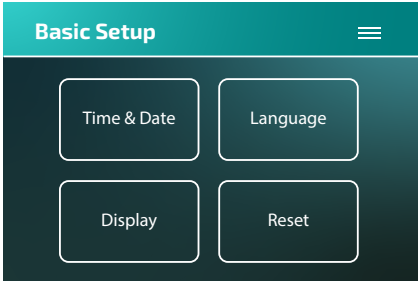

Swiping up and down on the screen can change the selected number to set the current time and date.  
 Sync with App: After enabling, when the inverter is communicating with the cloud platform via data logger, the inverter will keep the time in sync with cloud platform automatically.

**Basic Setup | Language** ☰

- English
- French
- Spanish
- Portuguse

On the "Language" page, you can set the display language of the LCD screen as needed.  
 Note: For current firmware version, only the English option is valid.

**Basic Setup | Display** ☰

**Brightness**

0%  100%

- LCD Auto Sleep Mode (5 mins)
- Beeper ON/OFF

**Brightness:** The screen brightness can be adjusted within the range of 0% to 100%  
**LCD Auto Sleep Mode(5 mins):** When it's enabled, the LCD screen will be dim automatically after 5 minutes of non-operation.  
**Beeper ON/OFF:** Used to turn on or off the beep sound in inverter's alarm status.

**Basic Setup | Reset** ☰

- Factory Reset
- Lock Out All Changes

**Factory Reset:** Reset all parameters of the inverter.  
**Lock Out All Changes:** After being checked, programmable parameters will be locked to prevent them from being changed.

# 6.6 Grid Setup Menu

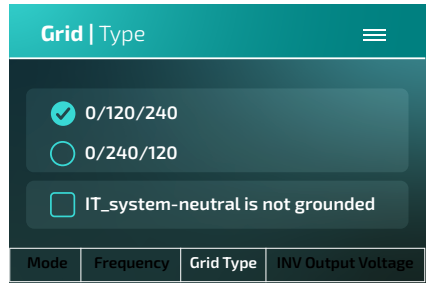
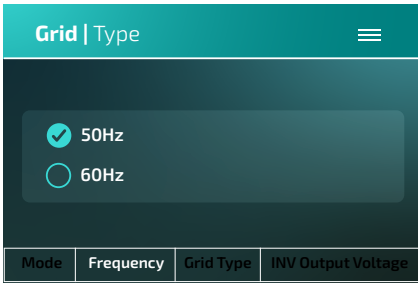
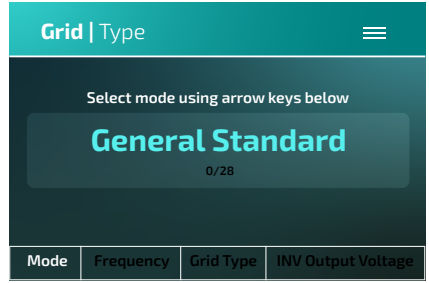
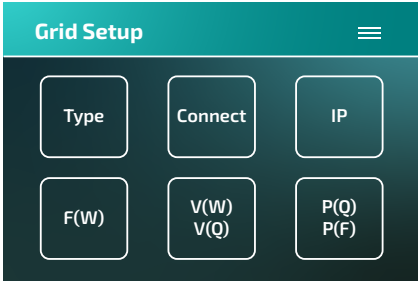

**Mode:** General Standard: UL1741 & IEEE1547, CPUC RULE21, SRD-UL-1741, CEI\_0\_21\_Internal, EN50549\_CZ-PPDS(>16A), Australia\_A, Australia\_B, Australia\_C, AS4777\_NewZealand, VDE4105, OVE-Directive R25, EN50549\_CZ\_PPDS\_L16A, NRS097, G98, G99, EN50549\_1\_Norway\_133V, EN50549\_1\_Norway\_230V, Japan\_200VAC, CEI\_0\_21\_External, CEI\_0\_21\_Areti, Japan\_400VAC\_3P3W, Japan\_415VAC\_3P4W, EN50549\_1\_Switzerland, EN50549\_1\_GR, EN50549\_1\_Poland, CEI\_0\_16\_IT, EN50549\_1, ESB\_Network\_Ireland.

Please follow the local grid code and then choose the corresponding grid standard.

IT\_system-neutral is not grounded: If the grid system is IT system, then please enable this option. All the live lines of IT system are insulated from ground, and the neutral point of the IT system is grounded through high impedance or not grounded (as shown in the following figure).

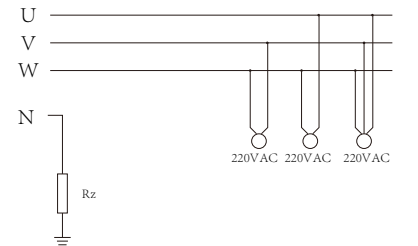

Rz: Large resistance ground resistor. Or the system doesn't have Neutral line

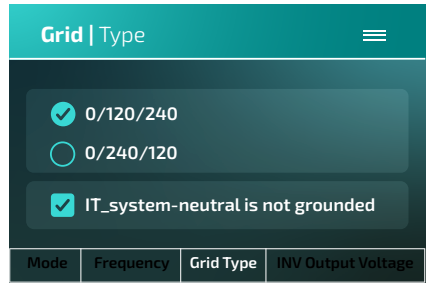

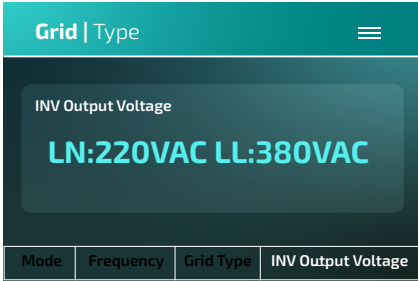

**INV Output Voltage:** there're several voltage levels for the inverter output voltage when it is in off-grid mode. LN:220VAC LL:380VAC, LN:230VAC LL:398VAC, LN:240VAC LL:415VAC, LN:120VAC LL:208VAC, LN:133VAC LL:220VAC, LN:115VAC LL:200VAC.

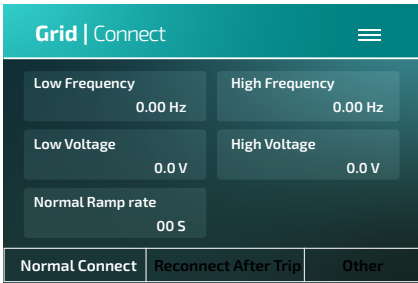

**Normal Connect:** The voltage and frequency range allowed for grid connection during the normal start-up process of the inverter.

**Normal Ramp rate:** The slope of the power climb of the inverter during normal startup process.

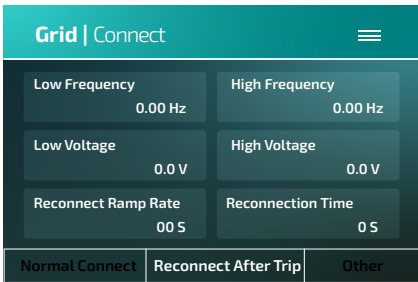

**Reconnect After Trip:** When the inverter is reconnected to the grid after tripping, the allowed voltage and frequency range for grid connection.

**Reconnection Time:** The waiting time for the inverter reconnects to the grid when the grid voltage/frequency return to the allowed range after tripping.

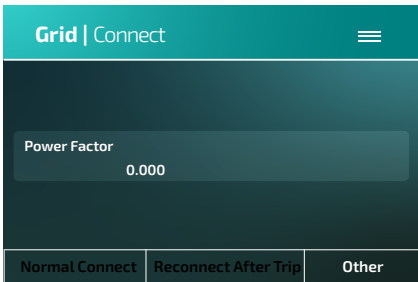

**Power Factor:** Power Factor is the ratio of active power to apparent power in the AC output circuit of the inverter.

Grid   IP			
Over Voltage U (10min, running mean)			0.0 V
HV1	0.0 V	0.00S	LV1
			0.0 V 0.00S
HV2	0.0 V	0.00S	LV2
			0.0 V 0.00S
HV3	0.0 V		LV3
			0.0 V
Voltage		Frequency	

Grid   IP			
HF1	0.00 Hz	0.00S	LF1
			0.00 Hz 0.00S
HF2	0.00 Hz	0.00S	LF2
			0.00 Hz 0.00S
HF3	0.00 Hz		LF3
			0.00 Hz
Voltage		Frequency	

**HV1:** Level 1 overvoltage protection point;  
**HV2:** Level 2 overvoltage protection point;  
**HV3:** Level 3 overvoltage protection point.  
**LV1:** Level 1 undervoltage protection point;  
**LV2:** Level 2 undervoltage protection point;  
**LV3:** Level 3 undervoltage protection point.  
**HF1:** Level 1 over frequency protection point;  
**HF2:** Level 2 over frequency protection point;  
**HF3:** Level 3 over frequency protection point.  
**LF1:** Level 1 under frequency protection point;  
**LF2:** Level 2 under frequency protection point;  
**LF3:** Level 3 under frequency protection point.

0.00 S—Trip time.

Grid   F(W)			
<input type="checkbox"/> P(Hf)	Start Delay F		
Start Frequency F	0.00 s		
0.00 HZ	Stop Delay F		
Stop Frequency F	0.00 s		
0.00 HZ	Droop F		
	0%PE/Hz		
Over Frequency		Under Frequency	

Grid   F(W)			
<input type="checkbox"/> P(Lf)	Start Delay F		
Start Frequency F	0.00 s		
0.00 HZ	Stop Delay F		
Stop Frequency F	0.00 s		
0.00 HZ	Droop F		
	0%PE/Hz		
Over Frequency		Under Frequency	

**F(W):** It's used to adjust the output active power of inverter according to the frequency of grid.  
**Droop F:** percentage of nominal power per Hz  
 For example, "Start freq F=50.2Hz, Stop freq F=51.5, Droop F=40%PE/Hz" when the grid frequency reaches 51.2Hz, the inverter will decrease its active power at rate of 40% per Hz. Then when frequency of grid is less than 50.2Hz, the inverter will stop decreasing output power.  
 For the detailed setup values, please follow the local grid code.

Grid   V(W)V(Q) <input type="checkbox"/> P(U) <span>☰</span>			
V1	0.0 %Un	P1	0 %
V2	0.0 %Un	P2	0 %
V3	0.0 %Un	P3	0 %
V4	0.0 %Un	P4	0 %
V(W)		V(Q)	

Grid   V(W)V(Q) <input type="checkbox"/> Q(U) <span>☰</span>				
Lock-in/Pn 0 %	V1	0.0 %Un	V2	0.0 %Un
	V3	0.0 %Un	V4	0.0 %Un
Lock-out/Pn 0 %	Q1	0 %	Q2	0 %
	Q3	0 %	Q4	0 %
	V(W)		V(Q)	

**V(W):** It is used to adjust the inverter's active power according to the set grid voltage.

For example: V2=110%, P2=20%. When the grid voltage reaches the 110% times of rated grid voltage, inverter output power will reduce its active output power to 20% rated power.

**V(Q):** It is used to adjust the inverter's reactive power according to the set grid voltage.

These two functions are used to adjust inverter's output power (active power and reactive power) when grid voltage changes.

**Lock-in/Pn:** When the output active power of the inverter drops to the preset lower threshold (such as 5% rated power), the inverter will automatically activate the V (Q) reactive power regulation function.

**Lock-out/Pn:** When the output active power of the inverter rises to the preset upper threshold (such as 90% rated power), the inverter will automatically switch off the V (Q) reactive power regulation function. When the grid voltage drops to 90% of the rated grid voltage of the inverter, the inverter can output up to 44% (the ratio to the rated apparent power) of reactive power, helping to stabilize the grid voltage at the grid connection point.

Grid   P(Q) P(F) <input type="checkbox"/> Q(P) <span>☰</span>			
P1	0 %	Q1	0 %
P2	0 %	Q2	0 %
P3	0 %	Q3	0 %
P4	0 %	Q4	0 %
P(Q)		P(F)	

Grid   P(Q) P(F) <input type="checkbox"/> PF(P) <span>☰</span>				
Lock-in/Pn 0.0 %	P1	0 %	P2	0 %
	P3	0 %	P4	0 %
Lock-out/Pn 0.0 %	F1	0.000	F2	0.000
	F3	0.000	F4	0.000
	P(Q)		P(F)	

**Q(P):** It is used to adjust the inverter's reactive power according to the set active power.

**P(F):** It is used to adjust the inverter's PF according to the set active power.

For the detailed setup values, please follow the local grid code.

**Lock-in/Pn:** When the output ratio of the active power of the inverter drops below this threshold, the P(F) regulation mechanism will be activated and take effect.

**Lock-out/Pn:** When the output ratio of the active power of the inverter reaches this threshold, the P(F) regulation mechanism will be switched off.

Note: only when the grid voltage is equal to or higher than 1.05 times of rated grid voltage, then the P(F) mode will take effect.

# 6.7 Battery Setup Menu

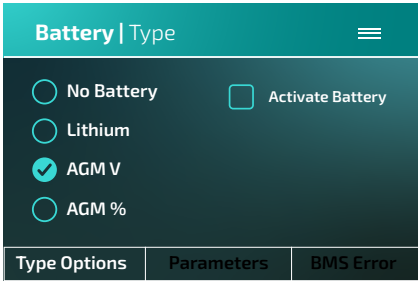
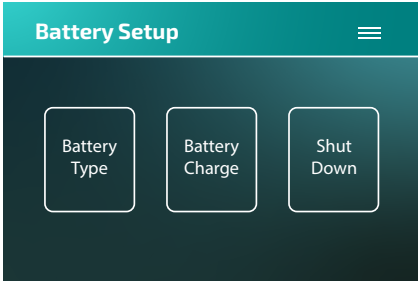

**No Battery:** tick this item if no battery is connected to the system.  
**AGM V:** Use battery voltage for setting all battery remaining capacity related parameters.  
**AGM %:** Use battery energy percentage for setting all battery remaining capacity related parameters.  
**Activate Battery:** This feature will help recover a battery that is over discharged by slowly charging from the solar array or grid.

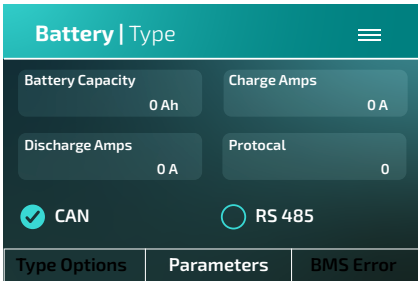

**Battery Capacity:** When you check "AGM %" mode, you need to type in the total capacity of your battery bank to align the battery SOC.  
**Charge/Discharge Amps:** Max battery charge/discharge current (0-120A for 5kW model, 0-150A for 6kW model, 0-190A for 8kW model, 0-210A for 10kW model, 0-240A for 12kW model).  
 . For AGM and Flooded, we recommend Ah battery size x 20% = Charge/Discharge amps.  
 . For Lithium, we recommend Ah battery size x 50% = Charge/Discharge amps.  
 . For Gel, follow manufacturer' s instructions.

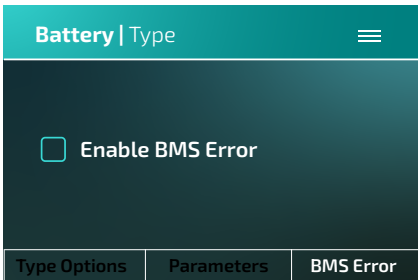

**Enable BMS Error:** When it is enabled, if the battery BMS failed to communicate with inverter, the inverter will stop working and report fault.

Battery   Charge		☰
<input type="checkbox"/> Gen Charge	Start	0.0 V
<input type="checkbox"/> Gen Signal	A	0 A
<input type="checkbox"/> Grid Charge	Start	0.0 V
<input type="checkbox"/> Grid Signal	A	0 A
Gen/Grid		Parameters

**This is Battery Setup page.**

**Gen Charge:** Allow the use of power input from the GEN port to charge the battery.

**Gen Signal:** The normally open relay will close when the battery SOC or voltage drop to the set value of "Start".

**Start:** When battery SOC or voltage drop to this set value, inverter will start the generator automatically via activating the "Gen Signal" to charge the battery.

**A:** The upper limit of charging current for charging batteries with power from generator connected to GEN port.

**This is Grid Charge, you need select.**

**Grid Charge:** It's allowed to use power fed from the grid port, which includes grid or generator connected to the grid port, to charge the battery.

**Grid Signal:** When a generator is connected to the grid port of hybrid inverter, this 'Grid signal' can be used to control the dry contact to start or stop the generator.

**Start:** When battery SOC or voltage drop to this set value, inverter will start the generator connected to the grid port automatically via activating the "Grid Signal" to charge the battery.

**A:** The upper limit of charging current for charging batteries with power from grid port.

Battery   Charge		☰
Float V	Absorption V	
0.0 V	0.0 V	
Equalization V	Equalization Days	
0.0 V	0 days	
Equalization Hours		
0.0 hours		
Gen/Grid		Parameters

Three stage charging strategy for lead-acid and incompatible lithium battery.

Battery   Shut Down		☰
Shut Down	Low Battery	
0.0 V	0.0 V	
Restart		
0.0 V		

**Shut Down:** Be valid in Off-grid mode, when battery SOC/ voltage drop to this value, then the DC/AC inverter module of this inverter will be shut down and the solar power can only be used to charge the battery.

**Low Battery:** Be valid in On-grid mode, when the "Grid charge" has been checked and the set target battery SOC/ voltage on "TOU" page isn't less than the "Low Battery" value, the battery SOC/voltage will remain above the value of "Low Battery".

**Restart:** Be valid in Off-grid mode, after the DC/AC inverter module of this inverter is shut down, the PV power can only be used to charge the battery. When the battery SOC/ Voltage has returned to this "Restart" value, the DC/AC inverter module will restart to output AC power.

# 6.8 Li BMS Menu

Li BMS	
Battery Voltage	0.00 V
Battery Current	0A
Battery Temperature	-00.0C
Total SOC	0%
Total SOH	0%
Battery Charge Voltage	0.0V
Charge Current Limit	0A
Discharge Current Limit	0A
Alarms: 0x0000 0x0000	

This is Battery detail page.

# 6.9 Fault Code Menu

Fault Code		
F29	Parallel_CANbus_Fault	2025-07-22 09:55
F41	Parallel_System_Stop	2025-07-22 09:51
F56	Dc_VoltLow_Fault	2025-07-22 09:20

Alarms Code    ID:2405042782    Occured

This is Fault Code detail page.  
Please refer to the corresponding content in Chapter 7-1 for troubleshooting solutions.

# 6.10 Aux Load Setup Menu

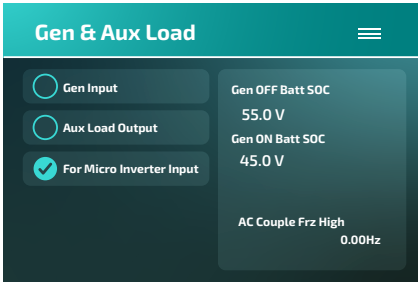
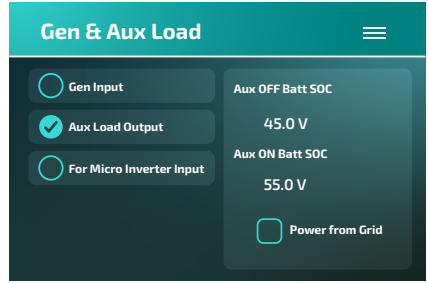
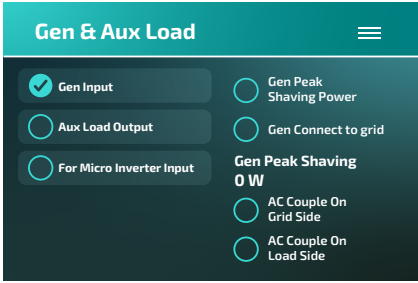

- Gen Input:** allowed Max. power from diesel generator.
  - Gen Peak Shaving Power:** Enable When the power of the generator exceeds the rated value of it, the inverter will provide the redundant part to ensure that the generator will not overload.
  - Gen Connect to grid:** connect the diesel generator to the grid input port.
  - AC Couple On Grid Side:** Connect one or several on-grid inverters on the Grid port side of this hybrid inverter.
  - AC Couple On Load Side:** Connect one or several on-grid inverters on the Load port side of this hybrid inverter.
  - Aux Load Output:** Use the GEN port as an AC output port, and the load connected to this port can be controlled on/off by the hybrid inverter.
    - **Aux OFF Batt SOC:** Battery SOC or voltage at which the Smart load will switch off.
    - **Aux ON Batt SOC:** Battery SOC or voltage at which the Smart load will switch on.
  - Power from Grid:** When "Power from Grid" is checked, the smart load port will always keep switching on if hybrid inverter is operating in on-grid mode.
  - For Micro Inverter Input:** Use the GEN port as an AC couple input port, which can be connected with micro-inverter or other Grid-Tied inverter.
    - **Gen OFF Batt SOC:** When the battery SOC or voltage rise to this set value and the hybrid inverter is operating in off-grid mode, the frequency of GEN port of hybrid inverter will be raised to 'AC Couple Frz High' to trip the Grid-tied inverter. It's invalid in on-grid mode.
    - **Gen ON Batt SOC:** When the battery SOC or voltage drops below this set value, the relay on GEN port of hybrid inverter will be switched on, then the Grid-Tied inverter will generate power and feed into hybrid inverter.
  - AC Couple Frz High:** If choosing "For Micro Inverter Input", as the battery SOC reaches gradually setting value (OFF), during the process, the microinverter output power will decrease linear. When the battery SOC equals to the setting value (OFF), the system frequency will become the setting value (AC couple Frz High) and the Microinverter will stop working.
- Note: Micro Inv Input OFF and On is valid for some certain FW version only.

# 6.11 System Mode Setup Menu

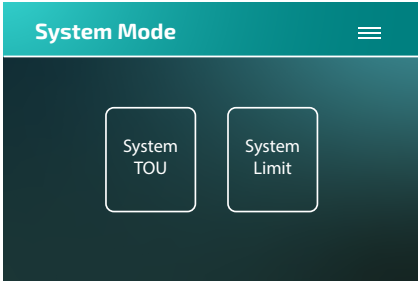

**System | TOU**

Use Timer

Time Start	Time End	Power	SOC/V	Grid	Gen
01:00	05:00	4000	49.0V	<input type="checkbox"/>	<input type="checkbox"/>
05:00	09:00	4000	49.0V	<input type="checkbox"/>	<input type="checkbox"/>
09:00	13:00	4000	49.0V	<input type="checkbox"/>	<input type="checkbox"/>
13:00	17:00	4000	49.0V	<input type="checkbox"/>	<input type="checkbox"/>
17:00	21:00	4000	49.0V	<input type="checkbox"/>	<input type="checkbox"/>
21:00	01:00	4000	49.0V	<input type="checkbox"/>	<input type="checkbox"/>

**System | Limit**

- Limit to Load
- Limit to Grid + Load
- Export Excess Solar
- Priority Load

Zero Export Power  
0W

Grid Peak Shaving  
Power  
0W

**Use Timer:** it is used to program when to use grid or generator to charge the battery, and when to discharge the battery to power the load. Only tick "Use Timer" then the follow items (Grid, charge, time, power etc.) will take effect.

**Time:** real time, range of 01:00-24:00.

**Power:** Max. discharge power of battery allowed.

**Note:** when the grid is present, only the "Use Timer" is ticked, then the battery will discharge. Otherwise, the battery won't discharge even the battery SOC is full. But in the off-grid mode (when grid is not available, inverter will work in the off-grid mode automatically).

**SOC/V:** The target value of battery voltage or SOC during the current time period. If the actual SOC or voltage of the battery is lower than this target value, the battery needs to be charged. If there is a energy source like solar power or grid, the battery will be charged; If the actual SOC or voltage of the battery is higher than this target value, the battery can discharge, and when the solar power is not enough to power the load , the battery will discharge.

**Grid:** utilize grid to charge the battery in a time period.

**Gen:** utilize diesel generator to charge the battery in a time period.

**Limit to Load:** Hybrid inverter will only provide power to the backup load connected. The hybrid inverter will neither provide power to the home load nor sell power to grid,if the "solar sell" behind is not enabled. The built-in CT will detect power flowing back to the grid and will reduce the power of the inverter only to supply the backup load and charge the battery.  
Load consumption=Backup load

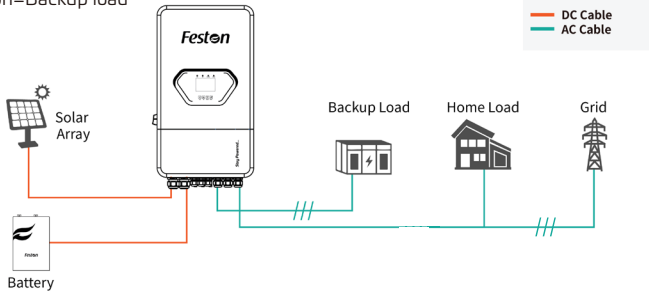

**Limit to Grid + Load:** Hybrid inverter will not only provide power to the backup load connected but also give power to the home load connected. If PV power and battery power is insufficient, it will take grid energy as supplement. The hybrid inverter will not sell power to grid, if the "solar sell" behind is not enabled. In this mode, external CTs or smart meter must be installed. For the installation method of CTs or smart meter, please refer to the section 3.7. The external CTs or smart meter will detect power flowing back to the grid and will reduce the power of the inverter only to supply the backup load, home load and charge the battery.  $\text{Load consumption} = \text{Backup load} + \text{home load}$

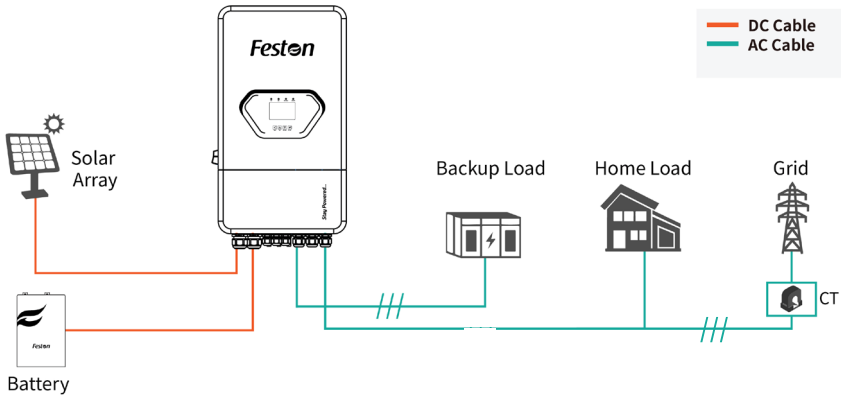

**Export Excess Solar:** "Export Excess Solar" is for Limit to Load or Limit to Grid + Load. When activating it, the surplus of the energy generated by the PV can be sold back to grid. When it is active, the energy generated by the PV array will first power the loads or charge the battery, and then export to grid.

**Priority Load:** PV power is firstly used to power the load, and the excess power will be used to charge the battery. If PV power is insufficient, Grid will provide power to load.

**Zero Export Power:** This parameter will ensure the zero-export by taking from the grid some small amount of energy that has been set with this value. It is recommended to set it as 20-100W to ensure the hybrid inverter won't feed power to grid.

**Grid Peak Shaving:** when it is active, grid power will be limited within the set value. If the grid peak-shaving power plus PV power plus battery power cannot meet the power consumption of the load after peak-shaving, the grid peak-shaving will be invalid, and the power taken from the grid can exceed this set value.

## 6.12 Quick Control Setup Menu

Quick Control
☰

- Force Generator
- Beeper Override
- LCD Auto Sleep Mode (5 mins)
- Allow Remote Control

**Force Generator:** When the generator is connected, it is forced to start the generator without meeting other conditions.

**Beeper Override:** Used to turn on or off the beep sound in inverter's alarm status.

**LCD Auto Sleep Mode (5 mins):** When it's enabled, the LCD screen will be dim automatically after 5 minutes of non-operation.

**Allow Remote Control:** Whether to enter the "Remote Control" mode, after entering the "Remote control" mode, EMS and other upper computers can read and write specific registers of the inverter.

# 6.13 Advance Setup Menu

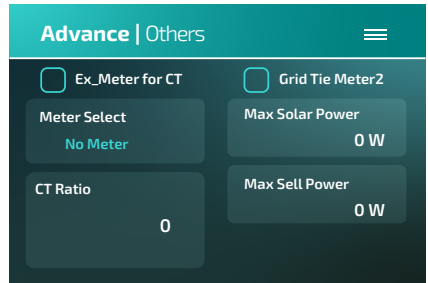
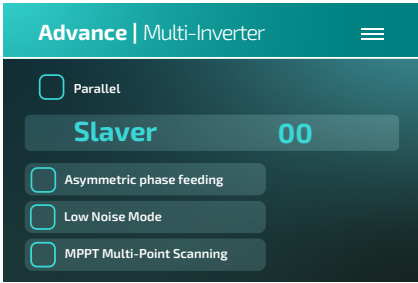
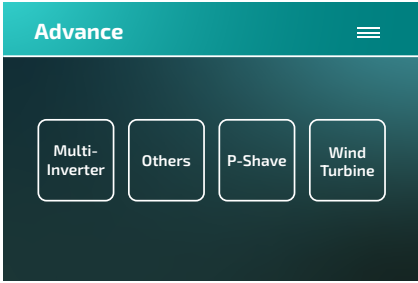

**Parallel:** Enable this function when several same model hybrid inverters are connecting in parallel.

**Master:** Select any hybrid inverter in the parallel system as the master inverter, and the master inverter needs to manage the working mode of the parallel system.

**Slaver:** Set the other inverters managed by the master inverter as slave inverter.

**Asymmetric phase feeding:** When the loads connected to the Load port have an unbalanced distribution on the three phases and the inverter is working in on-grid mode, enabling this function will ensure an equal power absorption from the three phases of grid.

**Low Noise Mode:** In this mode, the sound emitted by the inverter during operation will be smaller.

**MPPT Multi-Point Scanning:** After enabling this function, MPPT will perform I-V curve scanning every 5 minutes to find the maximum power point again and eliminate MPPT failure caused by shadows.

**Ex\_Meter for CT:** when using zero-export to CT mode, the hybrid inverter can select EX\_Meter For CT function and use the different meters.e.g.CHNT and Easton.

**Grid Tie Meter2:** When there are one or more grid-tied inverters AC coupled on the grid or load port side of the hybrid inverter, and an external meter is installed for this/these grid-tied inverters, it is necessary to enable this function to upload the data of the external meter to the hybrid inverter to ensure that the power consumption data of the load is correct.

**Meter Select:** select the corresponding meter type according to the meter installed in the system.

**CT Ratio:** When using an external CT alone, this parameter needs to be set. When using an external meter, it does not need to be set.

**Max Sell Power:** Maximum power allowed to flow to grid.

**Max Solar Power:** The maximum DC input power allowed.



System Selfcheck

Backup Delay

0 ms

Signal Island Mode

DRM

Solar Arc Fault ON

Clear Arc\_Fault

### Inverter

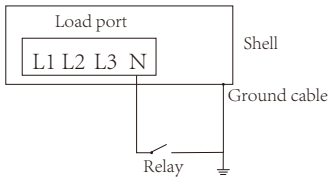

**System Selfcheck:** Disable. this is only for factory.

**Signal Island Mode:** If "Signal Island Mode" is checked and When inverter is in off-grid mode, the relay on the Neutral line (load port N line) will switch ON then the N line (load port N line) will bind to inverter ground. More details, please refer to left side picture.

**\* If this item was selected, please ensure that the shell of the inverter is grounded, otherwise there will be electric shock if you touch the shell.**

**DRM:** Demand response mode, receive external commands for active power scheduling and reactive power scheduling.

**Solar Arc Fault ON:** This feature is optional. After enabling this function, the inverter will detect whether there is an arcing fault on the PV side. If arcing occurs, the inverter will report a fault and stop outputting power.

**Clear Arc\_Fault:** After the arc fault on the PV side is eliminated, enabling this function can eliminate the arc fault alarm of the inverter and restore normal operation of the inverter.

**Backup Delay:** When the grid cuts off, the inverter will give output power after the setting time. For example, backup delay: 3ms. the inverter will give output power after 3ms when the grid cuts off.



DC1 for Wind Turbine

DC2 for Wind Turbine

V1	0 V	0.0 A	V7	0 V	0.0 A
V2	0 V	0.0 A	V8	0 V	0.0 A
V3	0 V	0.0 A	V9	0 V	0.0 A
V4	0 V	0.0 A	V10	0 V	0.0 A
V5	0 V	0.0 A	V11	0 V	0.0 A
V6	0 V	0.0 A	V12	0 V	0.0 A

**This is for Wind Turbine**

**DC 1 for WindTurbine:** Connect the wind turbine to the MPPT 1 of hybrid inverter.

**DC 2 for WindTurbine:** Connect the wind turbine to the MPPT 2 of hybrid inverter.

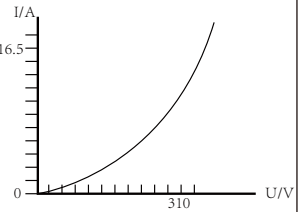

# 7. Mode

## Mode I: Basic

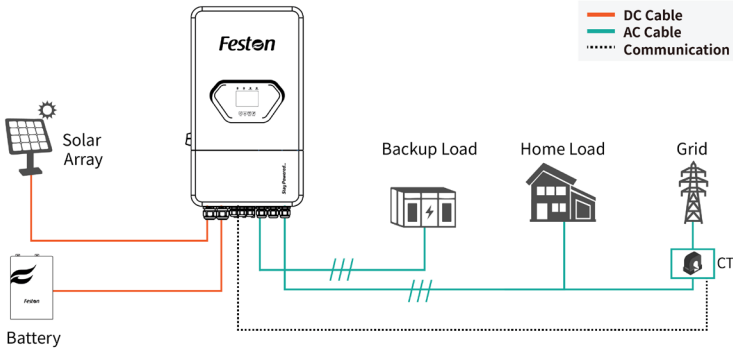

## Mode II: With Generator

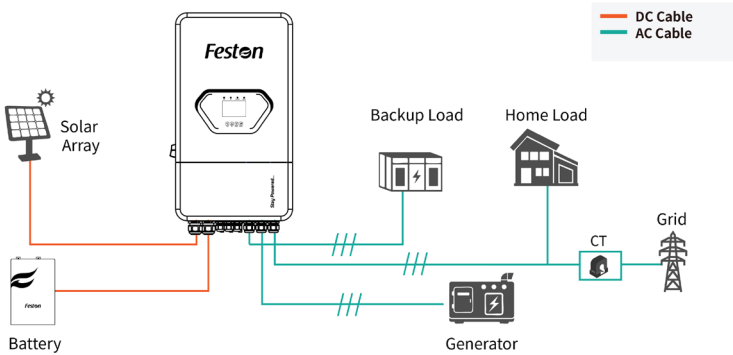

## Mode III: With Smart-Load

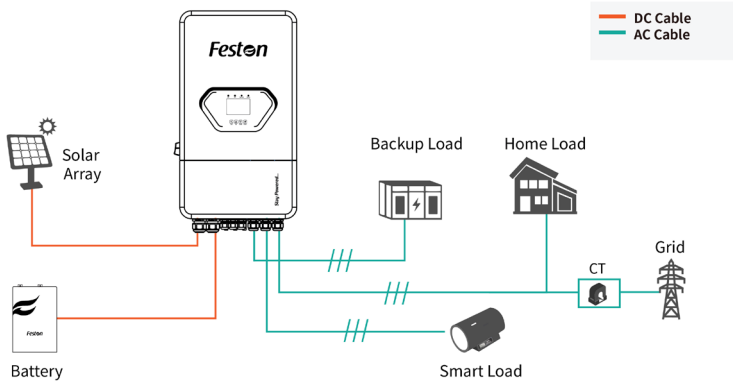

## Mode IV: AC Couple

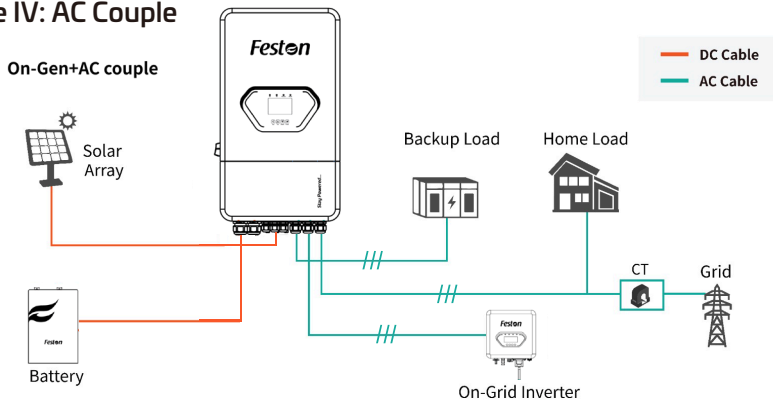

The 1st priority power of the system is always the PV power, then 2nd and 3rd priority power will be the battery bank or grid according to the settings. The last power backup will be the Generator if it is available.

## 8. Fault information and processing

Error code	Description	Solutions
F01	DC input polarity reverse fault	<ol style="list-style-type: none"> <li>1. Check the PV input polarity</li> <li>2. Seek help from us, if can not go back to normal state.</li> </ol>
F07	DC_START_Failure	<ol style="list-style-type: none"> <li>1. The BUS voltage can't be built from PV or battery.</li> <li>2. Restart the inverter, If the fault still exists, please contact us for help</li> </ol>
F13	working mode change	<ol style="list-style-type: none"> <li>1. When the grid type and frequency changed it will report F13;</li> <li>2. When the battery mode was changed to "No battery" mode, it will report F13;</li> <li>3. For some old FW version, it will report F13 when the system work mode changed;</li> <li>4. Generally, it will disappear automatically when shows F13;</li> <li>5. If still same, and turn off the DC switch and AC switch and wait for one minute and then turn on the DC/AC switch;</li> <li>6. Seek help from us, if can not go back to normal state.</li> </ol>
F15	AC over current fault of software	<p>AC side over current fault</p> <ol style="list-style-type: none"> <li>1. Please check whether the backup load power and common load power are within the range;</li> <li>2. Restart and check whether it is in normal;</li> <li>3. Seek help from us, if can not go back to normal state.</li> </ol>

<b>Error code</b>	<b>Description</b>	<b>Solutions</b>
F16	AC leakage current fault	Leakage current fault 1. Check the PV side cable ground connection 2. Restart the system 2-3 times 3. If the fault still exists, please contact us for help.
F18	AC over current fault of hardware	AC side over current fault 1. Please check whether the backup load power and commonload power are within the range; 2. Restart and check whether it is in normal; 3. Seek help from us, if cannot go back to normal state.
F20	DC over current fault of the hardware	DC side over current fault 1. Check PV module connect and battery connect; 2. When in the off-grid mode, the inverter startup with big power load, it may report F20. Please reduce the load power connected; 3. Turn off the DC switch and AC switch and then wait one minute, then turn on the DC/AC switch again; 4. Seek help from us, if can not go back to normal state.
F21	Tz_HV_Overcurr_fault	BUS over current. 1. Check the PV input current and battery current setting 2. Restart the system 2~3 times. 3. If the fault still exists, please contact us for help.
F22	Tz_EmergStop_Fault	Remotely shutdown 1. It tells the inverter is remotely controlled.
F23	Tz_GFCI_OC_current is transient over current	Leakage current fault 1. Check PV side cable ground connection. 2. Restart the system 2~3 times. 3. If the fault still exists, please contact us for help.
F24	DC insulation failure	PV isolation resistance is too low 1. Check the connection of PV panels and inverter is firmly and correctly; 2. Check whether the PE cable of inverter is connected to ground; 3. Seek help from us, if can not go back to normal state.
F26	The DC busbar is unbalanced	1. Please wait for a while and check whether it is normal; 2. When the load power of 3 phases is big different, it will report the F26. 3. When there's DC leakage current, it will report F26 4. Restart the system 2~3 times. 5. Seek help from us, if can not go back to normal state.
F29	Parallel CAN Bus fault	1. When in parallel mode, check the parallel communication cable connection and hybrid inverter communication address setting; 2. During the parallel system startup period, inverters will report F29. But when all inverters are in ON status, it will disappear automatically; 3. If the fault still exists, please contact us for help.

<b>Error code</b>	<b>Description</b>	<b>Solutions</b>
F34	AC Overcurrent fault	<ol style="list-style-type: none"> <li>1. Check the backup load connected, make sure it is in allowed power range</li> <li>2. If the fault still exists, please contact us for help</li> </ol>
F41	Parallel system stop	<ol style="list-style-type: none"> <li>1. Check the hybrid inverter work status. If there' lpgs hybrid inverter shutdown, all hybrid inverters will report F41 fault.</li> <li>2. If the fault still exists, please contact us for help</li> </ol>
F42	AC line low voltage	<p>Grid voltage fault</p> <ol style="list-style-type: none"> <li>1. Check the AC voltage is in the range of standard voltage inspecification;</li> <li>2. Check whether grid AC cables are firmly and correctly connected;</li> <li>3. Seek help from us, if can not go back to normal state.</li> </ol>
F46	backup battery fault	<ol style="list-style-type: none"> <li>1. Please check each battery status, such as voltage/ SOC and parameters etc., and make sure all the parameters are same.</li> <li>2. If the fault still exists, please contact us for help</li> </ol>
F47	AC over frequency	<p>Grid frequency out of range</p> <ol style="list-style-type: none"> <li>1. Check the frequency is in the range of specification or not;</li> <li>2. Check whether AC cables are firmly and correctly connected;</li> <li>3. Seek help from us, if can not go back to normal state.</li> </ol>
F48	AC lower frequency	<p>Grid frequency out of range</p> <ol style="list-style-type: none"> <li>1. Check the frequency is in the range of specification or not;</li> <li>2. Check whether AC cables are firmly and correctly connected;</li> <li>3. Seek help from us, if can not go back to normal state.</li> </ol>
F55	DC busbar voltage is too high	<p>BUS voltage is too high</p> <ol style="list-style-type: none"> <li>1. Check whether battery voltage is too high;</li> <li>2. check the PV input voltage, make sure it is within the allowed range;</li> <li>3. Seek help from us, if can not go back to normal state.</li> </ol>
F56	DC busbar voltage is too low	<p>Battery voltage low</p> <ol style="list-style-type: none"> <li>1. Check whether battery voltage is too low;</li> <li>2. If the battery voltage is too low, using PV or grid to charge thebattery;</li> <li>3. Seek help from us, if can not go back to normal state.</li> </ol>
F58	BMS communication fault	<ol style="list-style-type: none"> <li>1. it tells the communication between hybrid inverter and battery BMS disconnected when "BMS_Err-Stop" is active"</li> <li>2. if don't want to see this happen, you can disable "BMS_Err-Stop" item on the LCD;</li> <li>3. If the fault still exists, please contact us for help</li> </ol>
F62	DRMs0_stop	<ol style="list-style-type: none"> <li>1. Check the DRM function is active or not;</li> <li>2. Seek help from us, if can not go back to normal state after restart the system.</li> </ol>

<b>Error code</b>	<b>Description</b>	<b>Solutions</b>
F63	ARC fault	<ol style="list-style-type: none"> <li>1. Check PV module cable connection and clear the fault;</li> <li>2. Seek help from us, if can not go back to normal state.</li> </ol>
F64	Heat sink high temperature failure	<p>Heat sink temperature is too high</p> <ol style="list-style-type: none"> <li>1. Check whether the work environment temperature is too high;</li> <li>2. Turn off the inverter for 10mins and restart;</li> <li>3. Seek help from us, if can not go back to normal state.</li> </ol>

## Chart 8-1 Fault information

Under the guidance of our company, customers return our products so that our company can provide service of maintenance or replacement of products of the same value. Customers need to pay the necessary freight and other related costs. Any replacement or repair of the product will cover the remaining warranty period of the product. If any part of the product or product is replaced by the company itself during the warranty period, all rights and interests of the replacement product or component belong to the company.

Factory warranty does not include damage due to the following reasons:

- Damage during transportation of equipment;
- Damage caused by incorrect installation or commissioning;
- Damage caused by failure to comply with operation instructions, installation instructions or maintenance instructions;
- Damage caused by attempts to modify, alter or repair products;
- Damage caused by incorrect use or operation;
- Damage caused by insufficient ventilation of equipment;
- Damage caused by failure to comply with applicable safety standards or regulations;
- Damage caused by natural disasters or force majeure (e.g. floods, lightning, overvoltage, storms, fires, etc.)

In addition, normal wear or any other failure will not affect the basic operation of the product. Any external scratches, stains or natural mechanical wear does not represent a defect in the product.

## 9. Limitation of Liability

In addition to the product warranty described alone, the state and local laws and regulations provide financial compensation for the product's power connection (including violation of implied terms and warranties). The company hereby declares that the terms and conditions of the product and the policy can and can only legally exclude all liability within a limited scope.

# 10. Appendix I

## Definition of RJ45 Port Pin for BMS

No.	RS485 Pin
1	485_B
2	485_A
3	--
4	CAN-H
5	CAN-L
6	GND_485
7	485_A
8	485_B

BMS 485/CAN Port

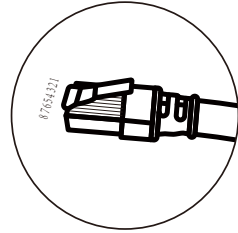
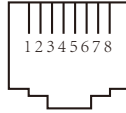

## Definition of RJ45 Port Pin for Meter-485

No.	Meter-485 Pin
1	METER-485-B
2	METER-485-A
3	COM-GND
4	METER-485-B
5	METER-485-A
6	COM-GND
7	METER-485-A
8	METER-485-B

Meter-485 Port

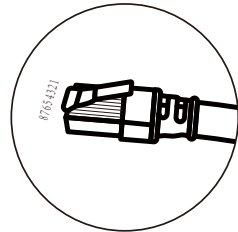

## Definition of RJ45 Port Pin of "Modbus port" for remotely monitoring

No.	Modbus port
1	SUNSPE-485_B
2	SUNSPE-485_A
3	GND_SUNSPE-485
4	--
5	--
6	GND_SUNSPE-485
7	SUNSPE-485_A
8	SUNSPE-485_B

Modbus port

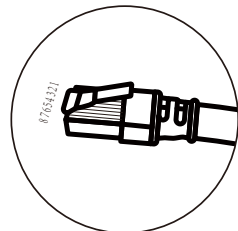

DRM: Only inverters with DRM function selected have this port.  
It is used to accept the external control command.

**Definition of RJ45 Port Pin for DRM**

No.	DRM
1	DI 1
2	DI 2
3	DI 3
4	DI 4
5	REF
6	GND
7	Reserved
8	Reserved

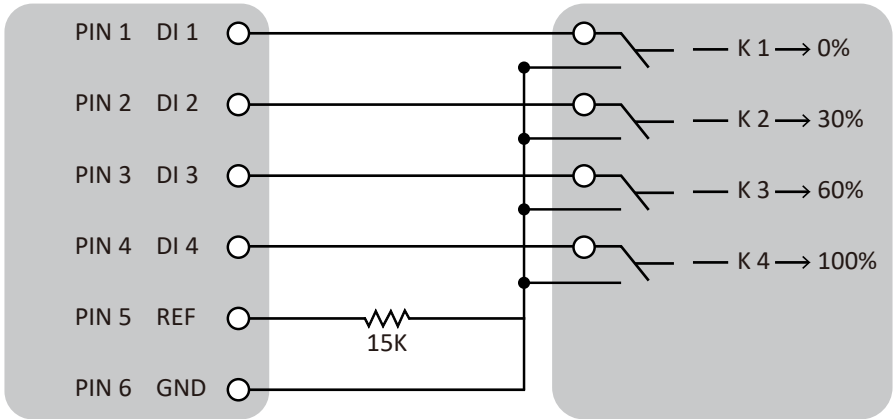
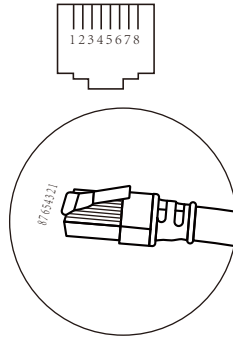

Inverter

RCR

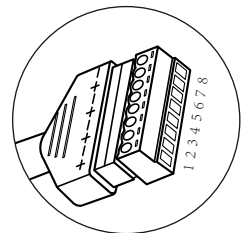
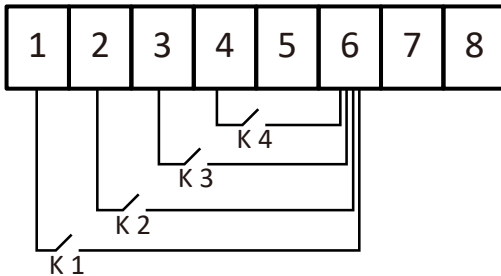
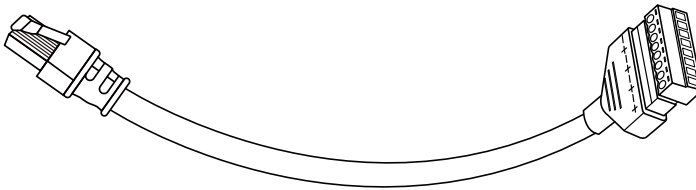

This model of inverter has two types of logger interfaces, DB9 and USB. Please refer to the actual inverter received for the actual interface type.

### RS232

No.	RS232
1	
2	TX
3	RX
4	
5	D-GND
6	
7	
8	
9	12Vdc

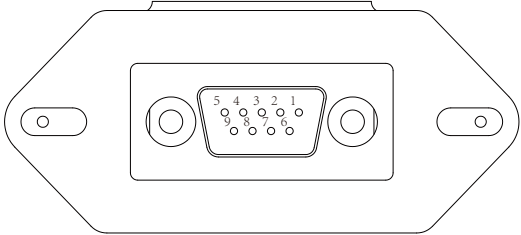

DB9 (RS232)

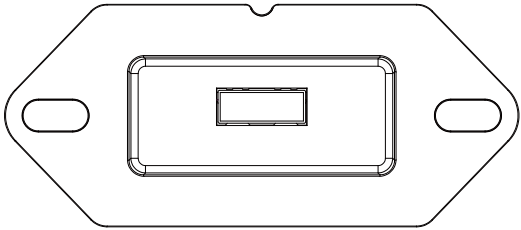

USB

## 11. Appendix II

1. Split Core Current Transformer (CT) dimension: (mm)
2. Secondary output cable length is 4m.

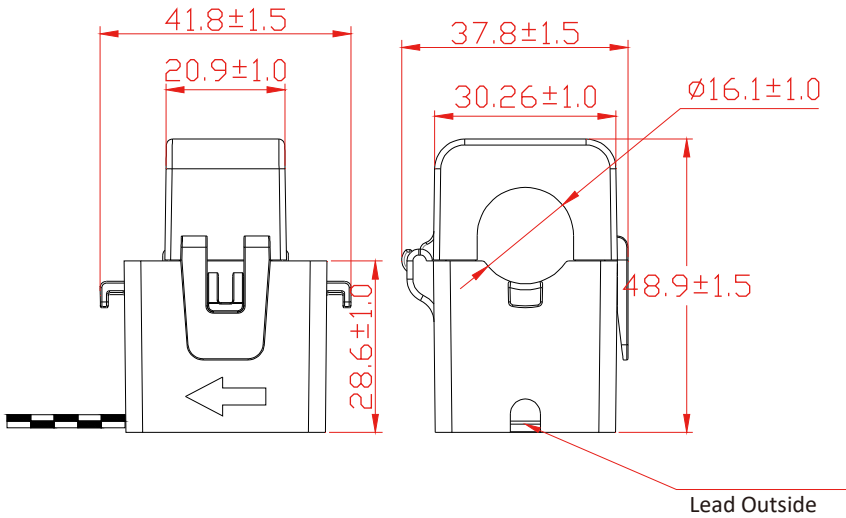



## FESTON S.E.V PRIVATE LIMITED



Add.: 3rd Floor, No. 97/80, Vanagaram Service Road, Athipattu,  
Ambattur, Chennai, Tamil Nadu, 600058, India

Tel.: +91 8925827701

E-mail: [sales@festonsev.com](mailto:sales@festonsev.com)

Web.: [www.festonsev.com](http://www.festonsev.com)