

Feston

USER MANUAL

Hybrid Inverter

FES-0336K-1PH-HB

FES-5K-1PH-HB

FES-6K-1PH-HB



Contents

1. Safety Introductions	01-02
2. Product instructions	02-08
2.1 Product Overview and Size	
2.2 Product Features	
2.3 Basic System Architecture	
3. Datasheet	08-09
4. Installation	10-32
4.1 Parts list	
4.2 Product handling requirements	
4.3 Mounting instructions	
4.4 Battery connection	
4.5 Grid connection and backup load connection	
4.6 PV Connection	
4.7 CT Connection	
4.7.1 Meter Connection	
4.8 Earth Connection(mandatory)	
4.9 WIFI Connection	
4.10 Wiring System for Inverter	
4.11 Single phase parallel connection diagram	
4.12 Three phase Parallel Inverter	
5. Operation	33
5.1 Power ON/OFF	
5.2 Operation and Display Panel	
6. LCD Display Icons	34-51
6.1 Main Screen	
6.2 Detail page	
6.3 Curve Page-Solar & Load & Grid	
6.4 SETTINGS Menu	
6.5 Basic Setup Menu	
6.6 Grid Setup Menu	
6.7 Battery Setup Menu	
6.8 Li BMS Menu	
6.9 Fault Code Menu	
6.10 Aux Load Setup Menu	
6.11 System Mode Setup Menu	
6.12 Quick Control Setup Menu	
6.13 Advance Setup Menu	
7. Mode	52-53
8. Fault information and processing	54-56
9. Limitation of Liability	56
10. Appendix I	57-58
11. Appendix II	59

About This Manual

The manual mainly describes the product information, guidelines for installation, operation and maintenance. The manual cannot include complete information about the photovoltaic (PV) system.

How to Use This Manual







Read the manual and other related documents before performing any operation on the inverter. Documents must be stored carefully and be available at all times.

Contents may be periodically updated or revised due to product development. The information in this manual is subject to change without notice.

1. Safety Introductions

- This chapter contains important safety and operating instructions. Read and keep this manual for future reference.
- Before using the inverter, please read the instructions and warning signs of the battery and corresponding sections in the instruction manual.
- Do not disassemble the inverter. If you need maintenance or repair, take it to a professional service center.
- Improper reassembly may result in electric shock or fire.
- To reduce risk of electric shock, disconnect all wires before attempting any maintenance or cleaning. Turning off the unit will not reduce this risk.
- Caution: Only qualified personnel can install this device with battery.
- Never charge a frozen battery.
- For optimum operation of this inverter, please follow required specification to select appropriate cable size. It is very important to correctly operate this inverter.
- Be very cautious when working with metal tools on or around batteries. Dropping a tool may cause a spark or short circuit in batteries or other electrical parts, even cause an explosion.
- Please strictly follow installation procedure when you want to disconnect AC or DC terminals. Please refer to "Installation" section of this manual for the details.
- Grounding instructions - this inverter should be connected to a permanent grounded wiring system. Be sure to comply with local requirements and regulation to install this inverter.
- Never cause AC output and DC input short circuited. Do not connect to the mains when DC input short circuits.

Labels description

Label	Description
	Caution, risk of electric shock symbol indicates important safety instructions, which if not correctly followed, could result in electric shock.
	The DC input terminals of the inverter must not be grounded.
	Surface high temperature, Please do not touch the inverter case.
	The AC and DC circuits must be disconnected separately, and the maintenance personnel must wait for 5 minutes before they are completely powered off before they can start working.
	CE mark of conformity
	Please read the instructions carefully before use.
	Symbol for the marking of electrical and electronics devices according to Directive 2002/96/EC. Indicates that the device, accessories and the packaging must not be disposed as unsorted municipal waste and must be collected separately at the end of the usage. Please follow Local Ordinances or Regulations for disposal or contact an authorized representative of the manufacturer for information concerning the decommissioning of equipment.

2. Product Introductions

This is a multifunctional inverter, combining functions of inverter, solar charger and battery charger to offer uninterruptible power support with portable size. Its comprehensive LCD display offers user configurable and easy accessible button operation such as battery charging, AC/solar charging, and acceptable input voltage based on different applications.

2.1 Product Overview and Size

FES-(0336-5)K-1PH-HB

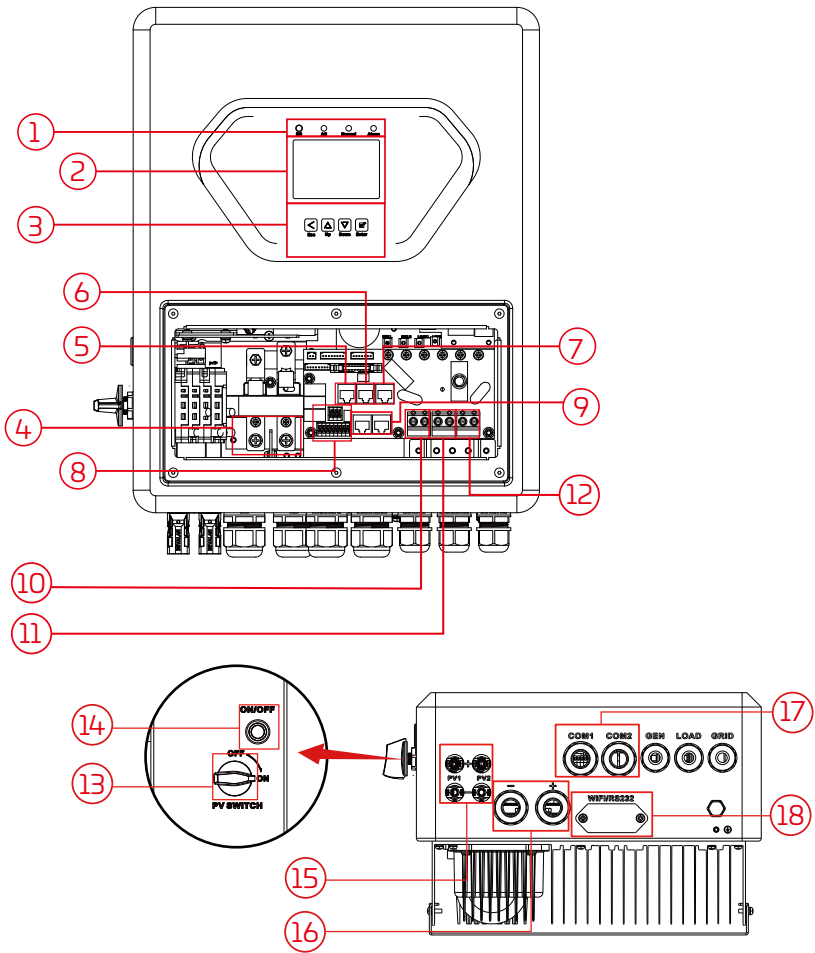

- | | | |
|-----------------------------|---------------------|----------------------------|
| 1: Inverter Indicators | 7: Meter Port | 13: DC Switch |
| 2: LCD display | 8: Function Port | 14: Power on/off button |
| 3: Function Buttons | 9: Parallel port | 15: PV input with two MPPT |
| 4: Battery input connectors | 10: Generator input | 16: Battery |
| 5: Modbus Port | 11: Load | 17: Temperature sensor |
| 6: RS485/CAN Port | 12: Grid | 18: WiFi Interface |

FES-(0336-5)K-1PH-HB

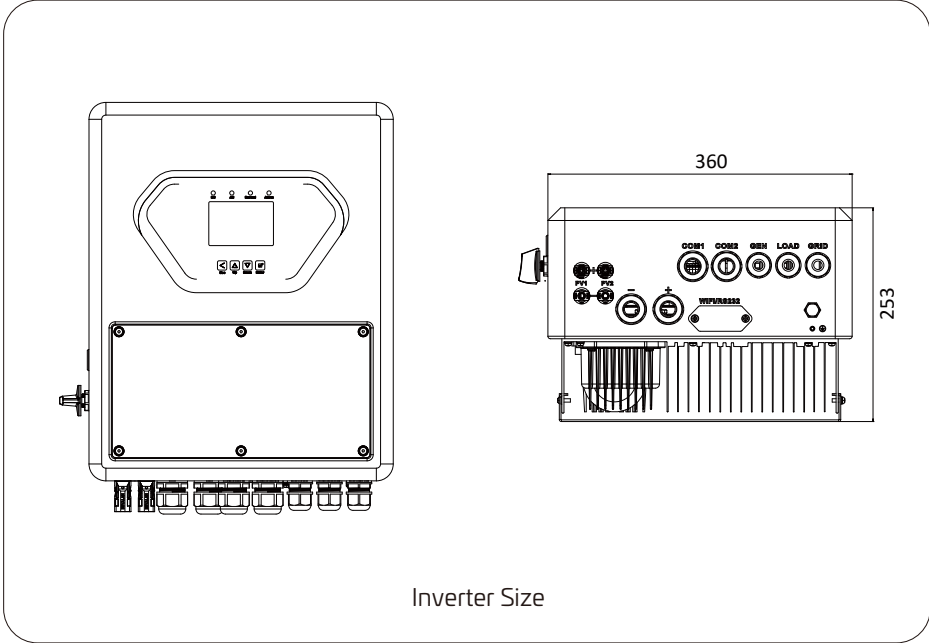

Inverter Size

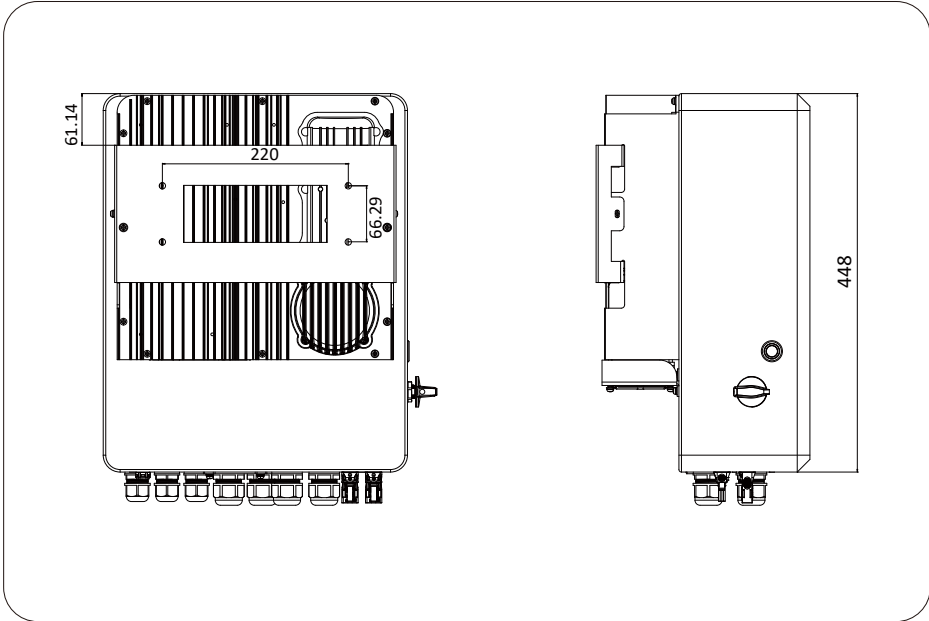

FES-6K-1PH-HB

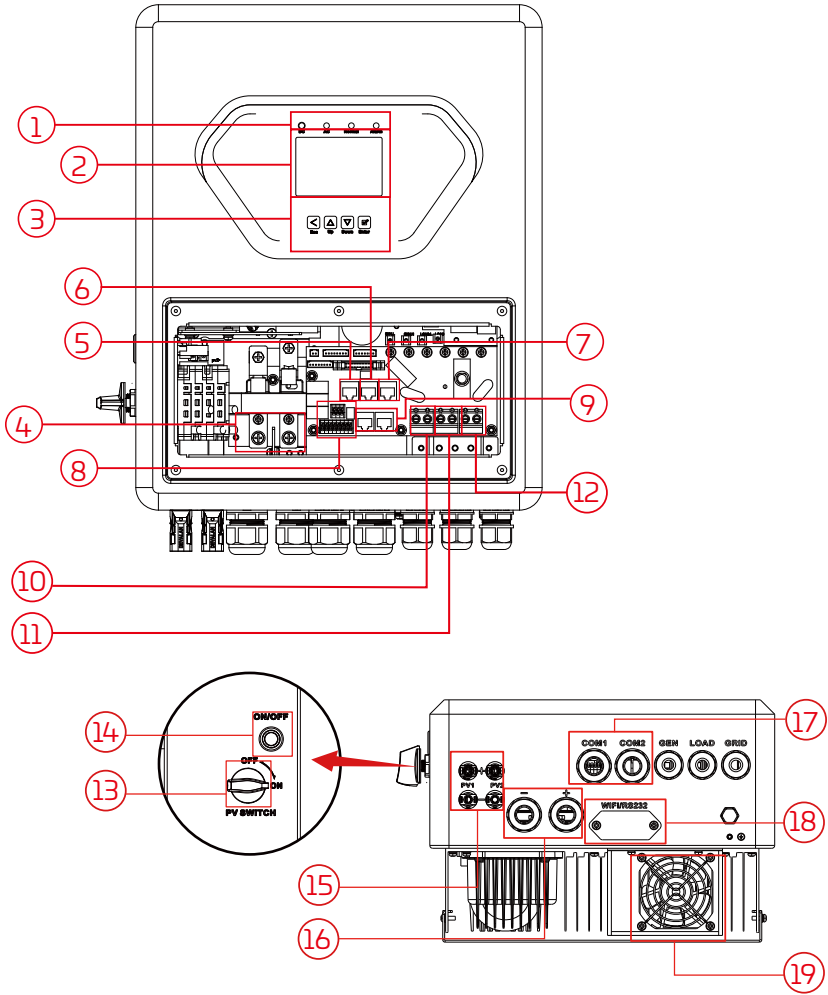

- | | | |
|-----------------------------|---------------------|----------------------------|
| 1: Inverter Indicators | 7: Meter Port | 13: DC Switch |
| 2: LCD display | 8: Function Port | 14: Power on/off button |
| 3: Function Buttons | 9: Parallel port | 15: PV input with two MPPT |
| 4: Battery input connectors | 10: Generator input | 16: Battery |
| 5: Modbus Port | 11: Load | 17: Temperature sensor |
| 6: RS485/CAN Port | 12: Grid | 18: WiFi Interface |
| | | 19: Fan |

FES-6K-1PH-HB

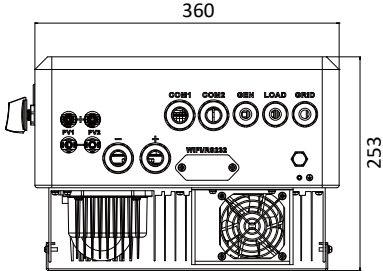
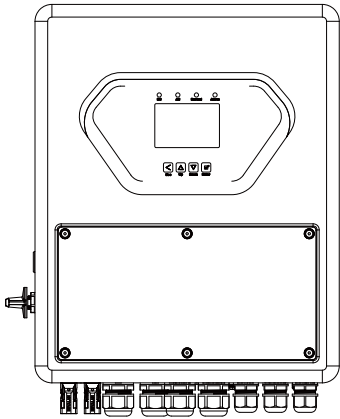

Inverter Size

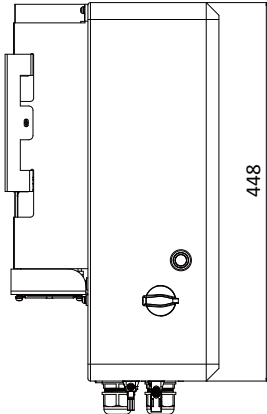
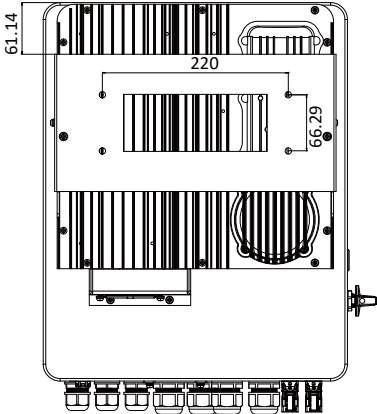

2.2 Product Features

- Self-consumption and feed-in to the grid.
- Auto restart while AC is recovering.
- Programmable supply priority for battery or grid.
- Programmable multiple operation modes: On grid, off grid and UPS.
- Configurable battery charging current/voltage based on applications by LCD setting.
- Configurable AC/Solar/Generator Charger priority by LCD setting.
- Compatible with mains voltage or generator power.
- Overload/over temperature/short circuit protection.
- Smart battery charger design for optimized battery performance
- With limit function, prevent excess power overflow to the grid.
- Supporting WIFI monitoring and build-in 2 strings of MPP trackers
- Smart settable three stages MPPT charging for optimized battery performance.
- Time of use function.
- Smart Load Function.

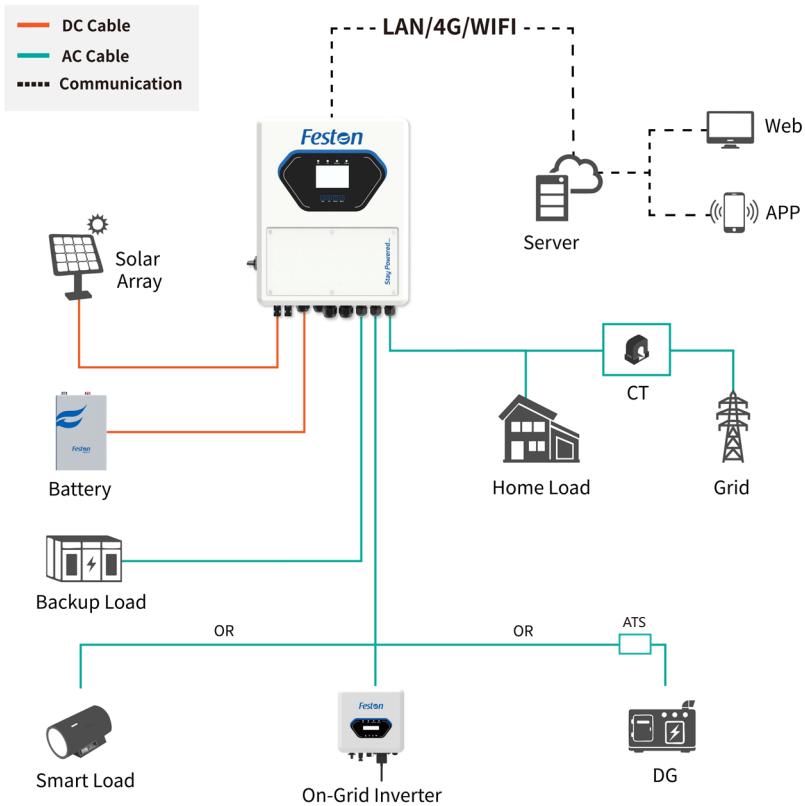

2.3 Basic System Architecture

The following illustration shows basic application of this inverter. It also includes following devices to have a Complete running system.

- Generator or Utility

- PV modules

Consult with your system integrator for other possible system architectures depending on your requirements.

This inverter can power all kinds of appliances in home or office environment, including motor type appliances such as refrigerator and air conditioner.

3. Datasheet

Model	FES-0336K-1PH-HB	FES-0336K-1PH-HB	FES-5K-1PH-HB	FES-6K-1PH-HB
Battery Input Data				
Battery Type	Lead-acid or Lithium-ion			
Battery Voltage Range(V)	40-60			
Max. Charging Current(A)	70	90	120	135
Max. Discharging Current(A)	70	90	120	135
Charging Strategy for Li-ion Battery	Self-adaptation to BMS			
Number of Battery Input	1			
PV String Input Data				
Max. PV access power(W)	6000	7200	10000	12000
Max. PV Input Power(W)	4800	5760	8000	9600
Max. PV Input Voltage(V)	500			
Start-up Voltage(V)	125			
PV Input Voltage Range(V)	125-500			
MPPT Voltage Range(V)	150-425			
Full Load MPPT Voltage Range(V)	300-425			
Rated PV Input Voltage(V)	370			
Max. Operating PV Input Current(A)	18	18+18		
Max. Input Short-Circuit Current(A)	27	27+27		
No. of MPP Trackers/No. of Strings MPP Tracker	1/1	2/1+1		
AC Input/Output Data				
Rated AC Input/Output Active Power(W)	3000	3600	5000	6000
Max. AC Input/Output Apparent Power(VA)	3300	3960	5500	6600
Peak Power (off-grid)(W)	2 times of rated power, 10s			
Rated AC Input/Output Current(A)	13.6/13	16.4/15.7	22.7/21.7	27.3/26.1
Max. AC Input/Output Current(A)	15/14.3	18/17.2	25/23.9	30/28.7
Max. Continuous AC Passthrough (grid to load)(A)	35			
Max. Output Fault Current(A)	30	36	50	60
Max. Output Overcurrent Protection(A)	70		80	
Rated Input/Output Voltage/Range(V)	220V/230V 0.85Un-1.1Un			
Grid Connection Form	L+N+PE			
Rated Input/Output Grid Frequency/Range	50Hz/45Hz-55Hz 60Hz/55Hz-65Hz			

Power Factor Adjustment Range	0.8 leading-0.8 lagging	
Total Current Harmonic Distortion THDi	<3% (of nominal power)	
DC Injection Current	<0.5%In	
Efficiency		
Max. Efficiency	97.60%	
Euro Efficiency	96.50%	
MPPT Efficiency	>99%	
Equipment Protection		
DC Polarity Reverse Connection Protection	Yes	
AC Output Overcurrent Protection	Yes	
AC Output Overvoltage Protection	Yes	
AC Output Short Circuit Protection	Yes	
Thermal Protection	Yes	
DC Terminal Insulation Impedance Monitoring	Yes	
DC Component Monitoring	Yes	
Ground Fault Current Monitoring	Yes	
Arc fault circuit interrupter (AFCI)	Optional	
Power Network Monitoring	Yes	
Island Protection Monitoring	Yes	
Earth Fault Detection	Yes	
DC Input Switch	Yes	
Overvoltage Load Drop Protection	Yes	
Residual Current (RCD) Detection	Yes	
Surge Protection Level	TYPE II(DC), TYPE II(AC)	
Interface		
Display	LCD+LED	
Communication Interface	RS232, RS485, CAN	
Monitor Mode	GPRS/WIFI/Bluetooth/4G/LAN(optional)	
General Data		
Operating Temperature Range	-40 to +60 C , >45 C Derating	
Permissible Ambient Humidity	0-100%	
Permissible Altitude	2000m	
Noise	<30 dB	
Ingress Protection(IP) Rating	IP 65	
Inverter Topology	Non-Isolated	
Over Voltage Category	OVC II(DC), OVC III(AC)	
Cabinet size(W*H*D) [mm]	360W×448H×253D (Excluding connectors and brackets)	
Weight(kg)	17	
Warranty	Standard 5 years, extendable warranty	
Type of Cooling	Natural Cooling	Intelligent Air Cooling
Grid Regulation	IEC 61727, IEC 62116, CEI 0-21, EN 50549, NRS 097, RD 140, UNE 217002, OVE-Richtlinie R25, G99, VDE-AR-N 4105	
Safety EMC/Standard	IEC/EN 61000-6-1/2/3/4, IEC/EN 62109-1, IEC/EN 62109-2	

4. Installation

4.1 Parts List

Check the equipment before installation. Please make sure nothing is damaged in the package. You should have received the items in the following package:

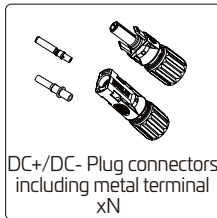
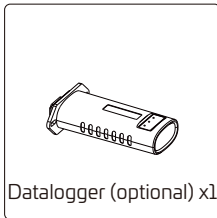
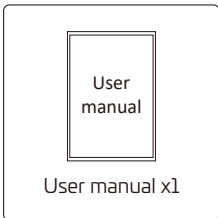
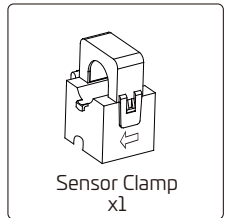
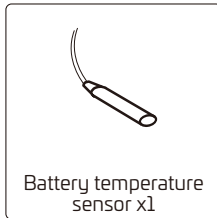
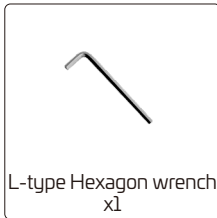
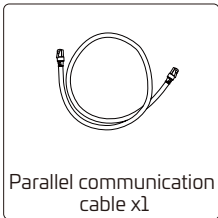
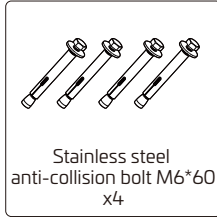
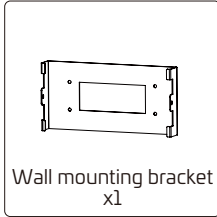
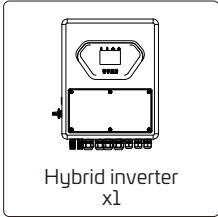

4.2 Product handling requirements

Lift the inverter out of the packing box and transport it to designated installation location.

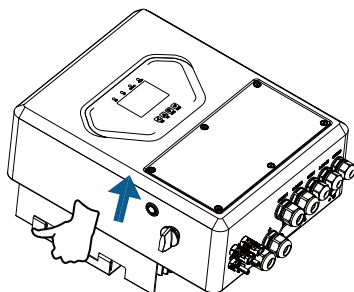

transport



CAUTION:

Improper handling may cause personal injury!

- Arrange an appropriate number of personnel to carry the inverter according to its weight, and installation personnel should wear protective equipment such as anti-impact shoes and gloves.
- Placing the inverter directly on a hard ground may cause damage to its metal enclosure. Protective materials such as sponge pad or foam cushion should be placed underneath the inverter.
- Move the inverter by one or two people or by using a proper transport tool.
- Move the inverter by holding the handles on it. Do not move the inverter by holding the terminals.

4.3 Mounting instructions

Installation Precaution

This Hybrid inverter is designed for outdoor use(IP65), Please make sure the installation site meets below conditions:





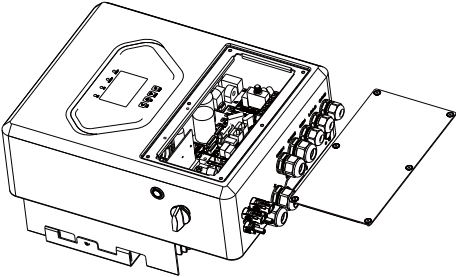







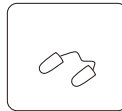

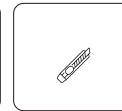
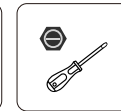
- Not in direct sunlight
- Not in areas where highly flammable materials are stored.
- Not in potential explosive areas.
- Not in the cool air directly.
- Not near the television Antenna or antenna cable.
- Not higher than altitude of about 2000 meters above sea level.
- Not in environment of precipitation or humidity(>95%)

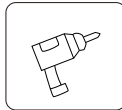
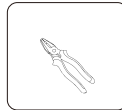
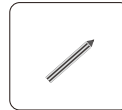
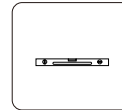
Please AVOID direct sunlight, rain exposure, snow laying up during installation and operation. Before connecting all wires, please take off the metal cover by removing screws as shown below:

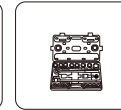

Installations Tools

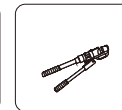
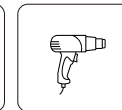
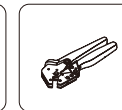
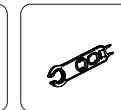
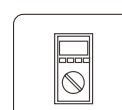
Installation tools can refer to the following recommended ones. Also, use other auxiliary tools on site.

						
Protective goggles	Anti-dust mask	Earplugs	Work gloves	Work shoes	Utility Knife	Slotted screwdriver
						
Cross screwdriver	Percussion drill	Pliers	Marker	Level	Rubber hammer	socket wrenches set
						
Anti-static wrist strap	Wire cutter	Wire stripper	Hydraulic pliers	Heat gun	Crimping tool4-6mm ²	Solar connector wrench
						
Multimeter ≥1100 Vdc	RJ45 crimping plier	Cleaner				

Considering the following points before selecting where to install:

- Please select a vertical wall with load-bearing capacity for installation, suitable for installation on concrete or other non-flammable surfaces, installation is shown below.
- Install this inverter at eye level in order to allow the LCD display to be read at all times.
- The ambient temperature is recommended to be between $-40\sim 60\text{ }^{\circ}\text{C}$ to ensure optimal operation.
- Be sure to keep other objects and surfaces as shown in the diagram to guarantee sufficient heat dissipation and have enough space for removing wires.

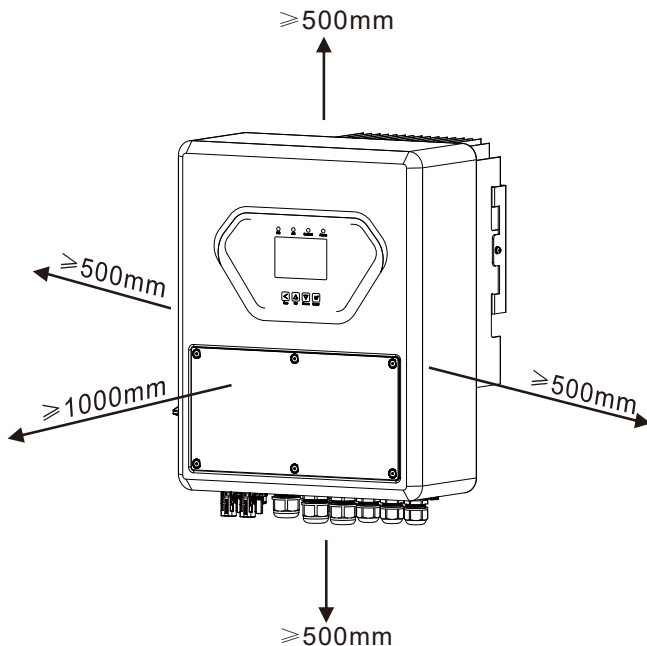

For proper air circulation to dissipate heat, allow a clearance of approx. 50cm to the side and approx. 50cm above and below the unit. And 100cm to the front.

Mounting the inverter

Remember that this inverter is heavy! Please be careful when lifting out from the package. Choose the recommend drill head(as shown in below pic) to drill 4 holes on the wall, 82-90mm deep.

1. Use a proper hammer to fit the expansion bolt into the holes.
2. Carry the inverter and holding it, make sure the hanger aim at the expansion bolt,fix the inverter on the wall.
3. Fasten the screw head of the expansion bolt to finish the mounting.

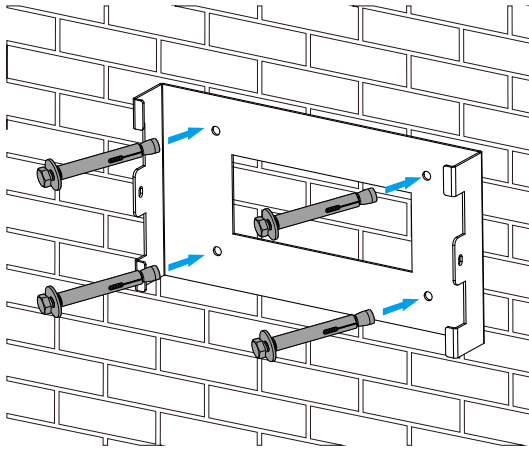

Inverter hanging plate installation

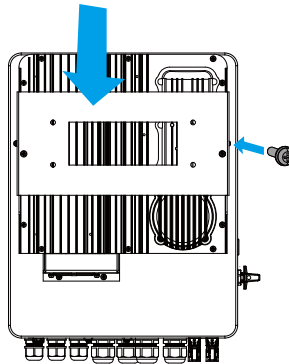

4.4 Battery connection

For safe operation and compliance, a separate DC over-current protector or disconnect device is required between the battery and the inverter. In some applications, switching devices may not be required but over-current protectors are still required. Refer to the typical amperage in the table below for the required fuse or circuit breaker size.

<i>Model</i>	<i>Cable(mm²)</i>	<i>Torque value(max)</i>
3kW	25	5.2Nm
3.6kW	25	5.2Nm
5kW	35	5.2Nm
6kW	35	5.2Nm

Chart 4-1 Cable size

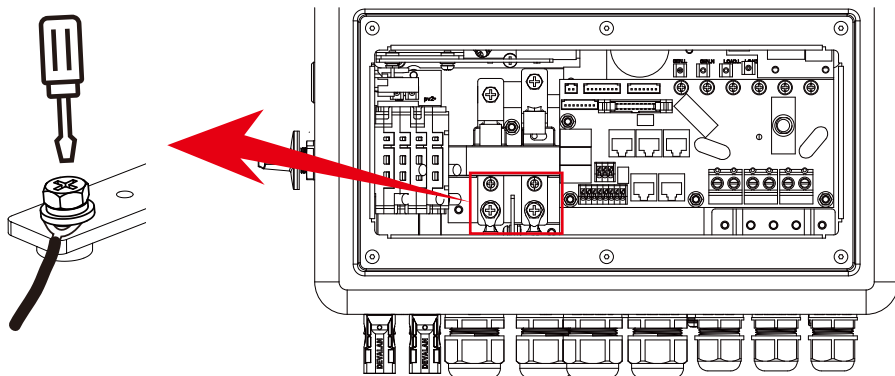

For 3kW/3.6kW/5kW/6kW model,
battery connector screw size: M6

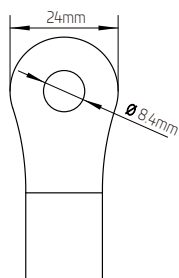

DC Battery Input

4. In case of children touch or insects go into the inverter, Please make sure the inverter connector is fasten to waterproof position by twist it clockwise.



Installation must be performed with care.



Before making the final DC connection or closing DC breaker/disconnect, be sure positive(+) must be connect to positive(+) and negative(-) must be connected to negative(-). Reverse polarity connection on battery will damage the inverter.

Battery Box:

The battery box is designed to house and protect the battery bank used in the solar power system. It provides a safe enclosure to prevent physical damage, maintain stable operating conditions, and ensure secure electrical connections.

The box helps in proper cable management and reduces risks from environmental factors such as dust, moisture, and accidental contact.

GA DIAGRAM FOR BATTERY BOX

FRONT VIEW

SIDE VIEW

BOTTOM VIEW

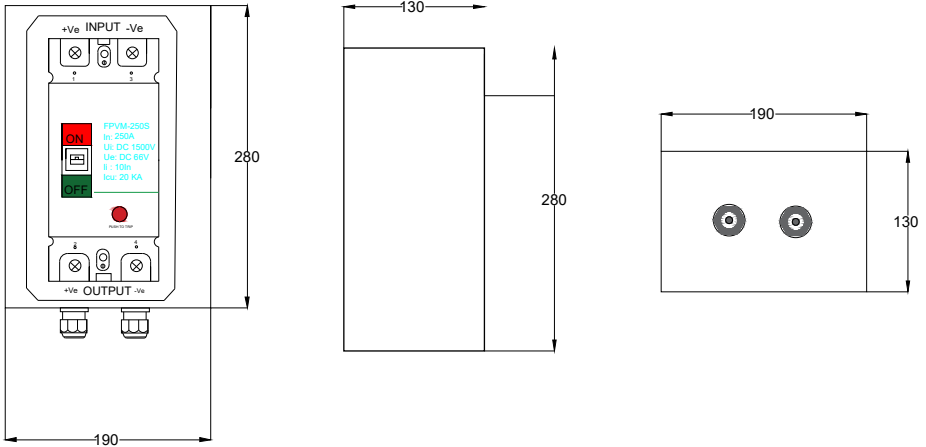

Battery Box

SL.NO	DESCRIPTION	RATING	QTY
1	ENCLOSURE(PC)	190X280X130	1
2	DC MCCB	2POLE 250A, 66V	1
3	CABLE GLANDS	PG21	4

Caution:

1. Ensure the battery box is well-ventilated to prevent heat buildup and gas accumulation.
2. Keep away from direct sunlight, rain, and flammable materials.
3. Always disconnect the battery terminals before performing any maintenance work.

Model	Charging/Discharging Current (A)	Recommended Breaker Size (A)
3.0	70	100
3.6	90	125
5.0	120	160
6.0	135	200

Points to remember for Installation:

1. Ensure the battery is placed securely at the installation location and correctly connected to the battery box, maintaining proper polarity. Even small polarity errors can lead to severe damage.
2. Connect the positive (+) terminal of the battery to the corresponding positive terminal of the inverter's battery input via the DCDB or tapped connection.
3. Connect the negative (-) terminal of the battery to the corresponding negative terminal of the inverter's battery input.
4. Tighten all terminals securely to avoid loose connections, and close the battery after completing the connections.

4.4.1 Function port definition

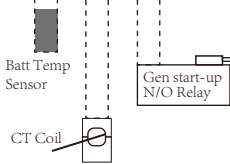
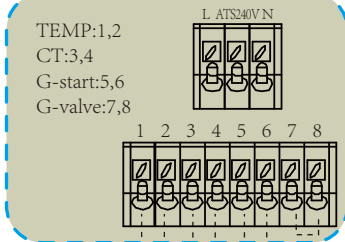
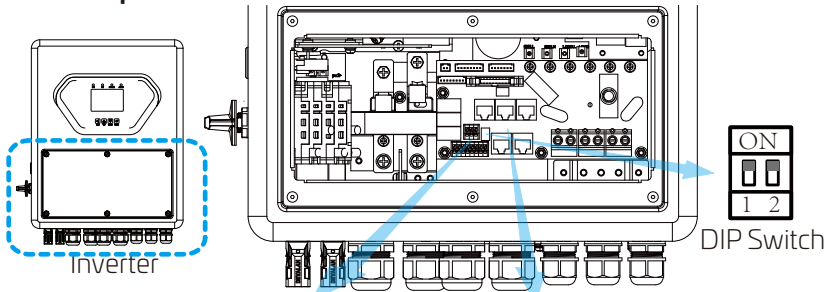

TEMP(1,2): battery temperature sensor for lead acid battery.

CT(3,4): current transformer for "zero export to CT" mode.

G-start/G-valve(5,6/7,8): dry contact signal for startup the diesel generator.

When the "GEN signal" is active, the open contact (GV/GS) will switch on (no voltage output). If the "Signal ISLAND MODE" is ticked, the GS port will be the dry contact signal for startup the diesel generator. If "Signal ISLAND MODE" is not ticked, the GV port will be the dry contact signal for startup the diesel generator.

ATS: If the conditions are met, it will output 230Vac.

DIP switch: Parallel communication resistor. If the number of inverters in the parallel system is less than or equal to 6, all inverter's DIP switch (1&2) need be ON position.

If the number of inverters in parallel system exceeds 6, the main 6pcs inverter's DIP switch needs to be ON position. And the other inverter DIP switch (1&2) needs to be OFF position.

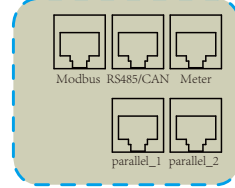

Modbus: Reserved.

RS485/CAN: For battery communication.

Meter: For energy meter communication.

Parallel 1: Parallel communication port 1 (CAN interface).

Parallel 2: Parallel communication port 2 (CAN interface).

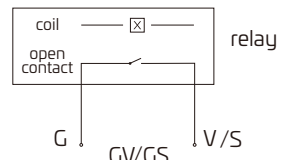

(diesel generator startup signal)

4.4.2 Temperature sensor connection for lead-acid battery

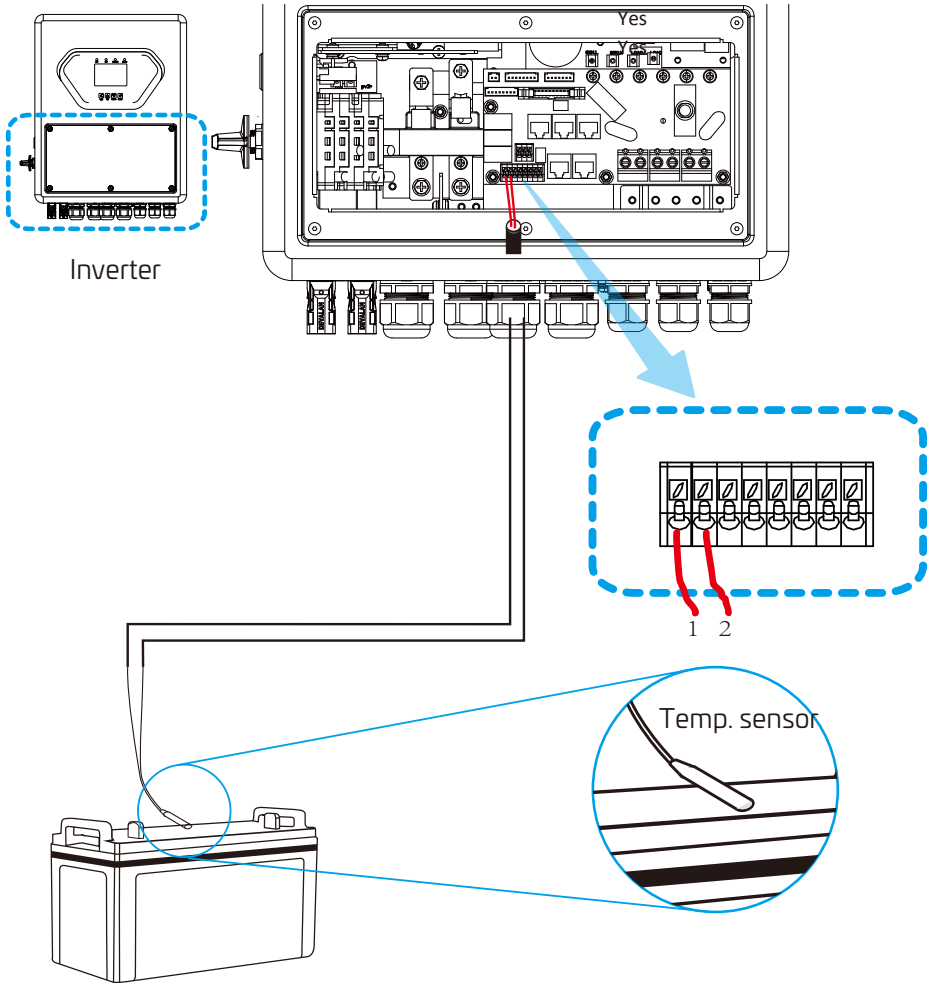

FES-(0336-5)K-1PH-HB

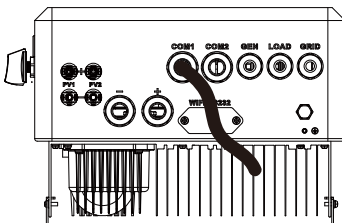

FES-6K-1PH-HB

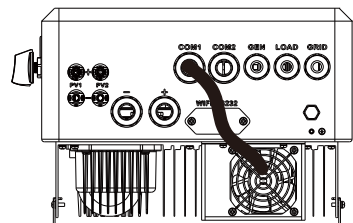

4.5 Grid connection and backup load connection

- Before connecting to the grid, a separate AC breaker must be installed between the inverter and the grid, and also between the backup load and the inverter. This will ensure the inverter can be securely disconnected during maintenance and fully protected from over current. For the 3/3.6/5/6kW model, the recommended AC breaker for backup load is 40A. For the 3/3.6/5/6kW model, the recommended AC breaker for grid is 40A.
- There are three terminal blocks with "Grid" "Load" and "GEN" markings. Please do not misconnect input and output connectors.



Note:

In final installation, breaker certified according to IEC 60947-1 and IEC 60947-2 shall be installed with the equipment.

All wiring must be performed by a qualified personnel. It is very important for system safety and efficient operation to use appropriate cable for AC input connection. To reduce risk of injury, please use the proper recommended cable as below.

Grid connection and backup load connection (Copper wires)

<i>Model</i>	<i>Wire Size</i>	<i>Cable(mm²)</i>	<i>Torque value(max)</i>
3kW	10AWG	4.0	1.2Nm
3.6/5/6kW	8AWG	6.0	1.2Nm

Grid connection and backup load connection (Copper wires) (Bypass)

<i>Model</i>	<i>Wire Size</i>	<i>Cable(mm²)</i>	<i>Torque value(max)</i>
3/3.6/5/6kW	8AWG	6.0	1.2Nm

Chart 4-2 Recommended Size for AC wires

Please follow below steps to implement AC input/output connection:

1. Before making Grid, load and Gen port connection, be sure to turn off AC breaker or disconnecter first.
2. Remove insulation sleeve 10mm length, unscrew the bolts, insert the wires according to polarities indicated on the terminal block and tighten the terminal screws. Make sure the connection is complete.

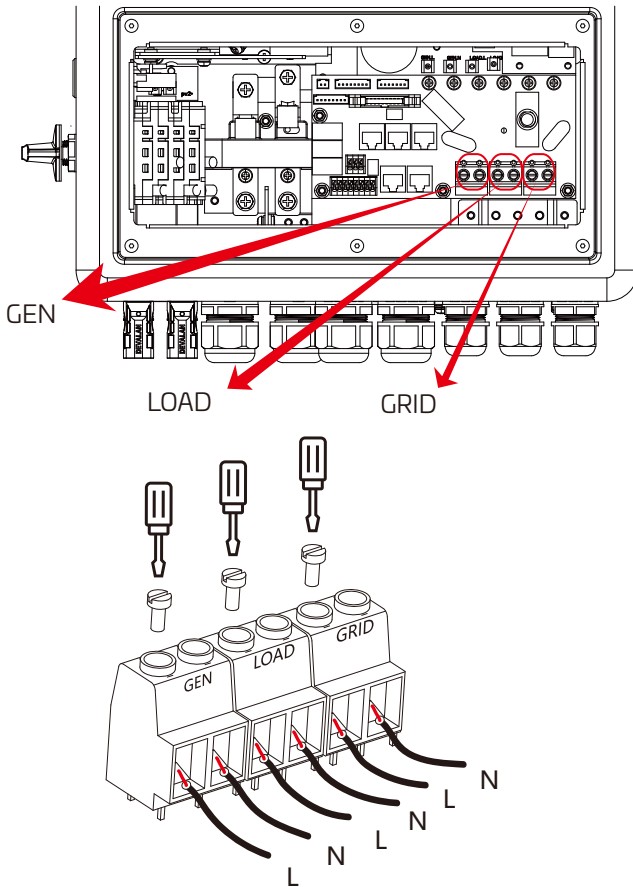

Be sure that AC power source is disconnected before attempting to wire it to the unit.

3. Then, insert AC output wires according to polarities indicated on the terminal block and tighten terminal. Be sure to connect corresponding N wires and PE wires to related terminals as well.
4. Make sure the wires are securely connected.
5. Appliances such as air conditioner are required at least 2-3 minutes to restart because it is required to have enough time to balance refrigerant gas inside of circuit. If a power shortage occurs and recovers in short time, it will cause damage to your connected appliances. To prevent this kind of damage, please check manufacturer of air conditioner if it is equipped with time-delay function before installation. Otherwise, this inverter will trigger overload fault and cut off output to protect your appliance but sometimes it still causes internal damage to the air conditioner

ACDB(AC Distribution Box) Installation Instructions:

The AC Distribution Box (ACDB) is used to safely route and protect the AC output from the solar inverter before it is supplied to the load or the utility grid. It houses protective devices such as MCBs, MCCBs, and surge protection devices to safeguard the system from overloads, short circuits, and voltage surges. The ACDB ensures controlled distribution of AC power and provides isolation for maintenance activities.

GA DIAGRAM FOR ACDB

FRONT VIEW

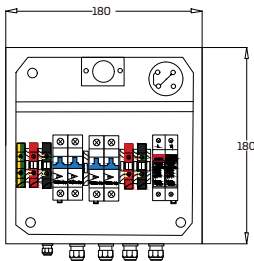

SIDE VIEW

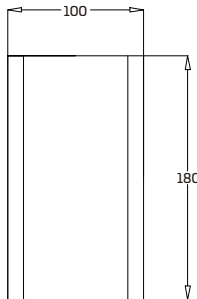

BOTTOM VIEW

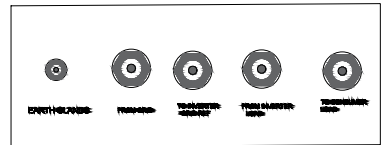

Caution

1. Ensure the ACDB is installed in such a way that it complies with the specified IP rating.
2. Do not work on the ACDB while the system is ON. Disconnect the inverter and grid supply before start of the installation.
3. Only qualified personnel should perform installation or maintenance.

Points to remember for Installation

1. Mount the ACDB securely on a wall or a strong surface at a convenient operating height.
2. Connect the AC output from the inverter to the input terminals of the ACDB using appropriately rated cables.
3. Connect the output terminals of the ACDB to the load or utility grid connection point.
4. Ensure proper grounding of the ACDB for safety.
5. Verify that all breakers and protection devices inside the ACDB are correctly rated and firmly secured before switching ON

4.6 PV Connection

Before connecting to PV modules, please install a separately DC circuit breaker between inverter and PV modules. It is very important for system safety and efficient operation to use appropriate cable for PV module connection. To reduce risk of injury, please use the proper recommended cable size as below.

<i>Model</i>	<i>Wire Size</i>	<i>Cable(mm²)</i>
3/3.6/5/6kW	12AWG	2.5

Chart 4-3 Cable size



To avoid any malfunction, do not connect any PV modules with possible current leakage to the inverter. For example, grounded PV modules will cause current leakage to the inverter. When using PV modules, please ensure the PV+ & PV- of solar panel is not connected to the system ground bar.



It is requested to use PV junction box with surge protection. Otherwise, it will cause damage on inverter when lightning occurs on PV modules.

4.6.1 PV Module Selection:

When selecting proper PV modules, please be sure to consider below parameters:

- 1) Open circuit Voltage (Voc) of PV modules not exceeds max. PV array open circuit voltage of inverter.
- 2) Open circuit Voltage (Voc) of PV modules should be higher than min. start voltage.
- 3) The PV modules used to connected to this inverter shall be Class A rating certified according to IEC 61730.

<i>Inverter Model</i>	<i>3kW</i>	<i>3.6kW</i>	<i>5kW</i>	<i>6kW</i>
PV Input Voltage	370V (125V-500V)			
PV Array MPPT Voltage Range	150V-425V			
No. of MPP Trackers	1	2		
No. of Strings per MPP Tracker	1	1+1	1+1	1+1

Chart 4-4

4.6.2 PV Module Wire Connection:

1. Switch the Grid Supply Main Switch(AC)OFF.
2. Switch the DC Isolator OFF.
3. Assemble PV input connector to the inverter.



Safety Hint:

When using PV modules, please ensure the PV+ & PV- of solar panel is not connected to the system ground bar.



Safety Hint:

Before connection, please make sure the polarity of the output voltage of PV array matches the "DC+" and "DC-" symbols.



Safety Hint:

Before connecting inverter, please make sure the PV array open circuit voltage is within the 500V of the inverter.

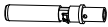
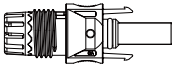

Pic 4.1 DC+ male connector

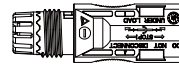

Pic 4.2 DC- female connector



Safety Hint:

Please use approved DC cable for PV system.

The steps to assemble the DC connectors are listed as follows: a) Strip off the DC wire about 7mm, disassemble the connector cap nut (see picture 4.3).

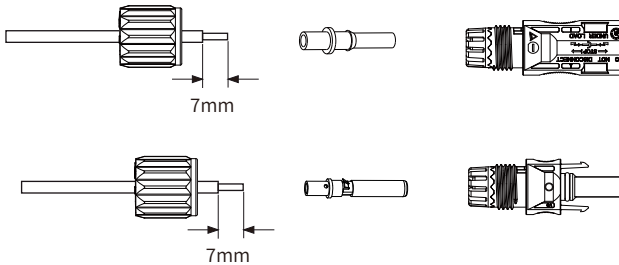

Pic 4.3 Disassemble the connector cap nut

b) Crimping metal terminals with crimping pliers as shown in picture 4.4.

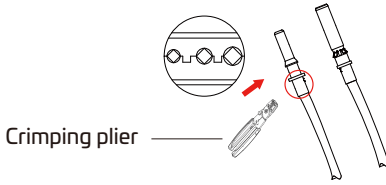

Pic 4.4 Crimp the contact pin to the wire

c) Insert the contact pin to the top part of the connector and screw up the cap nut to the top part of the connector. (as shown in picture 4.5).

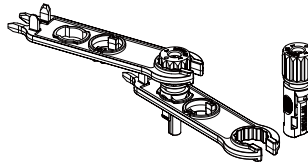

Pic 4.5 connector with cap nut screwed on

d) Finally insert the DC connector into the positive and negative input of the inverter, shown as picture 4.6.

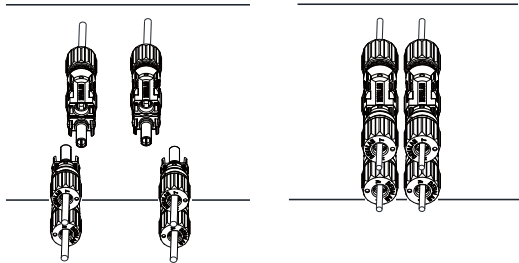

Pic 4.6 DC input connection



Warning:

Sunlight shines on the panel will generate voltage, high voltage in series may cause danger to life. Therefore, before connecting the DC input line, the solar panel needs to be blocked by the opaque material and the DC switch should be 'OFF', otherwise, the high voltage of the inverter may lead to life-threatening conditions.

DCDB(DC Distribution Box) Installation Instructions:

The DC distribution box is used to combine and control the DC output from the solar panels before it enters the inverter. It has protection devices such as DC circuit breakers, fuses, and surge protection units, ensuring safe operation, fault isolation, and protection of the inverter from overcurrent and voltage surges.

Caution

1. Ensure the DCDB is installed in such a way that it complies with the specified IP rating.
2. Always switch off the inverter before performing maintenance or inspection.
3. Verify correct polarity connections from the solar panels to prevent damage to internal components.

NOTE: Ensure the PV panels are disconnected or covered before starting work to avoid live DC voltage.

GA DIAGRAM FOR DCDB

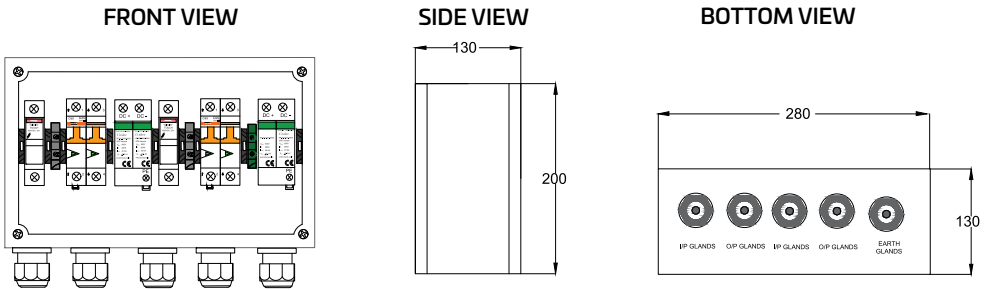

Points to remember for Installation:

1. Identify the positive and negative output cables from the solar combiner box.
2. Use the recommended DC cable size as per inverter specifications.
3. Connect the positive wire from the combiner box to the DC MCB or fuse inside the DCDB.
4. Connect the negative wire from the combiner box to the negative busbar in the DCDB.
5. Ensure the DC SPD is connected between the positive and negative terminals inside the DCDB.
6. From the DCDB output terminals, connect the positive and negative cables to the DC input terminals of the inverter.
7. Check all terminals for firm and secure connections, avoiding loose wiring.
8. Close DCDB securely before turning ON the system.

4.7 CT Connection

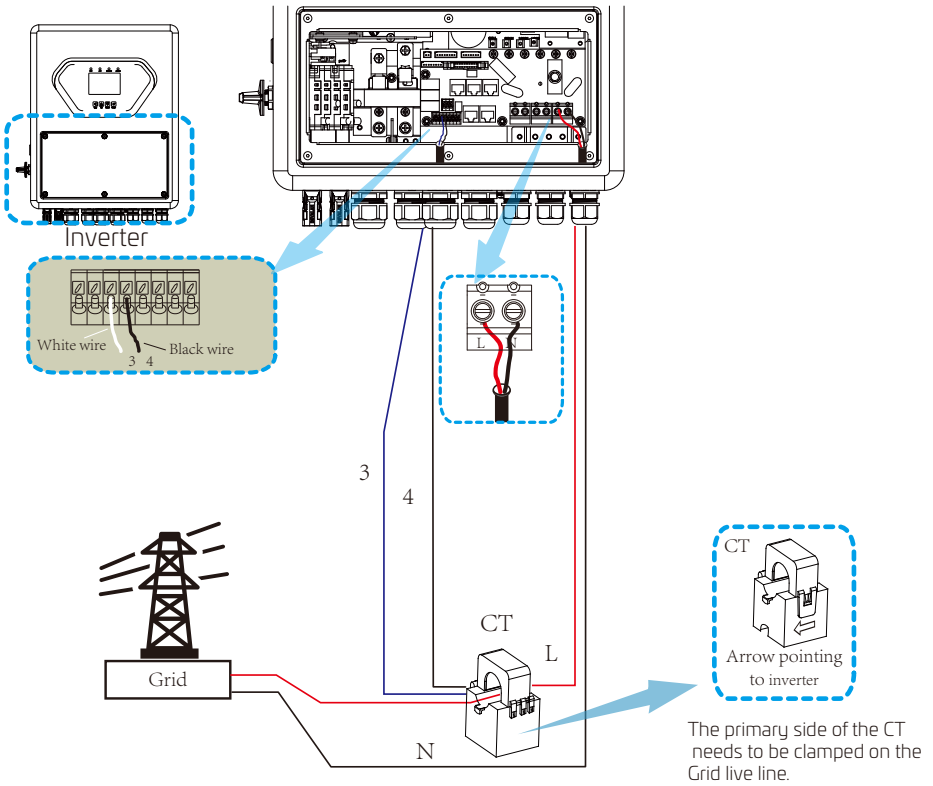

***Note:** when the reading of the load power on the LCD is not correct, please reverse the CT arrow.

4.7.1 Meter Connection

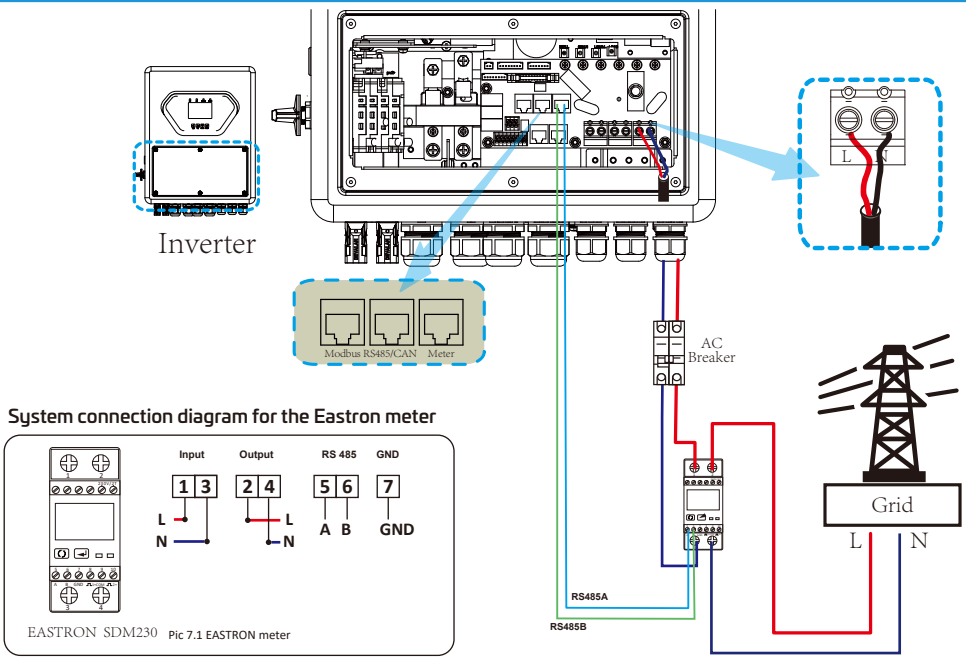
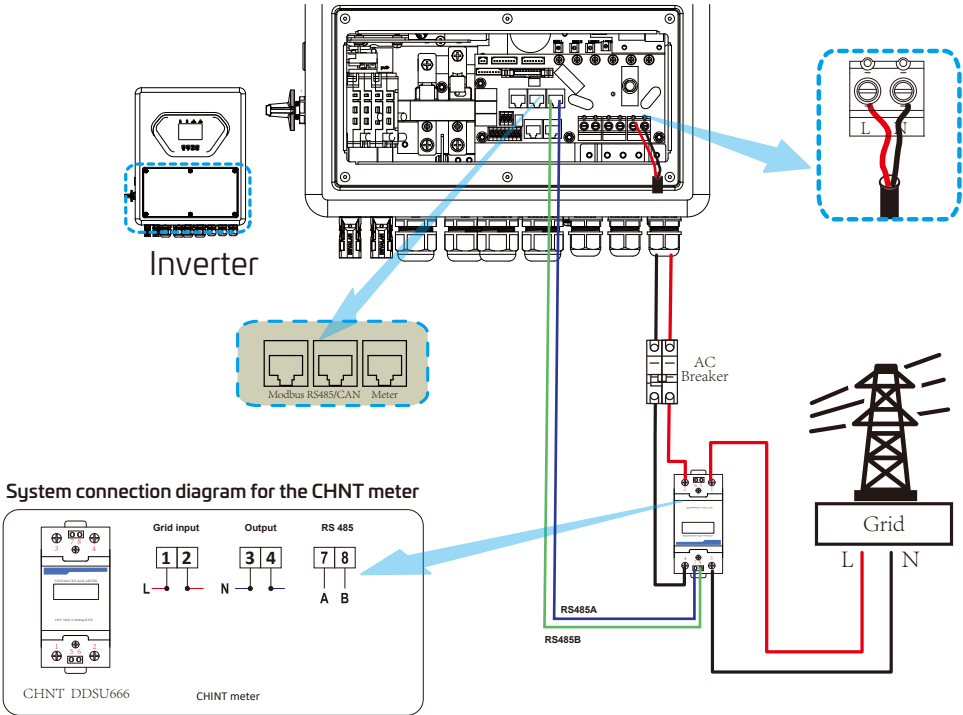

4.8 Earth Connection(mandatory)

Ground cable shall be connected to ground plate on grid side, this prevents electric shock if the original protective conductor fails.

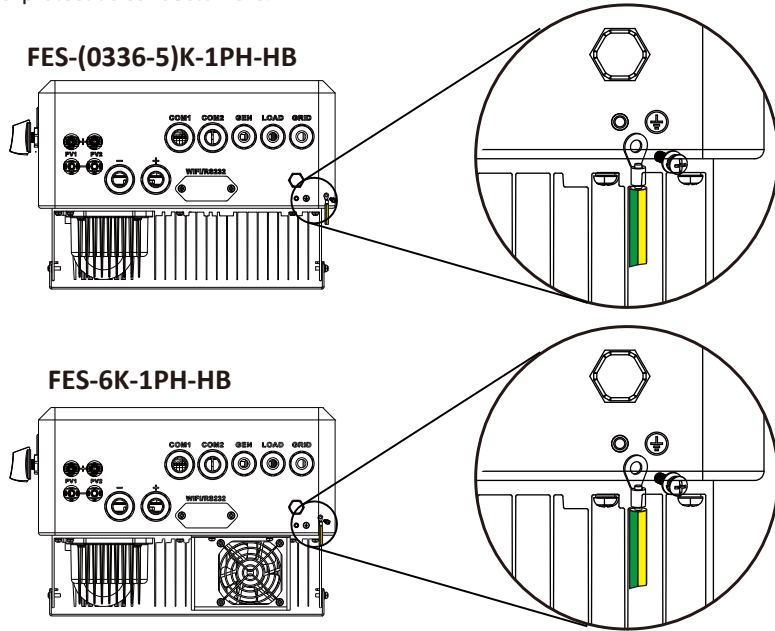

Earth connection (Copper wires)

Model	Wire Size	Cable(mm ²)	Torque value(max)
3kW	10AWG	4.0	1.2Nm
3.6/5/6kW	8AWG	6.0	1.2Nm

Earth connection (Copper wires) (Bypass)

Model	Wire Size	Cable(mm ²)	Torque value(max)
3/3.6/5/6kW	8AWG	6.0	1.2Nm



Warning:

Inverter has built-in leakage current detection circuit, The type A RCD can be connected to the inverter for protection according to the local laws and regulations. If an external leakage current protection device is connected, its operating current must be equal to 300 mA or higher, otherwise inverter may not work properly.

4.9 WIFI Connection

For the configuration of Wi-Fi Plug, please refer to illustrations of the Wi-Fi Plug. The Wi-Fi Plug is not a standard configuration, it's optional.

4.10 Wiring System for Inverter

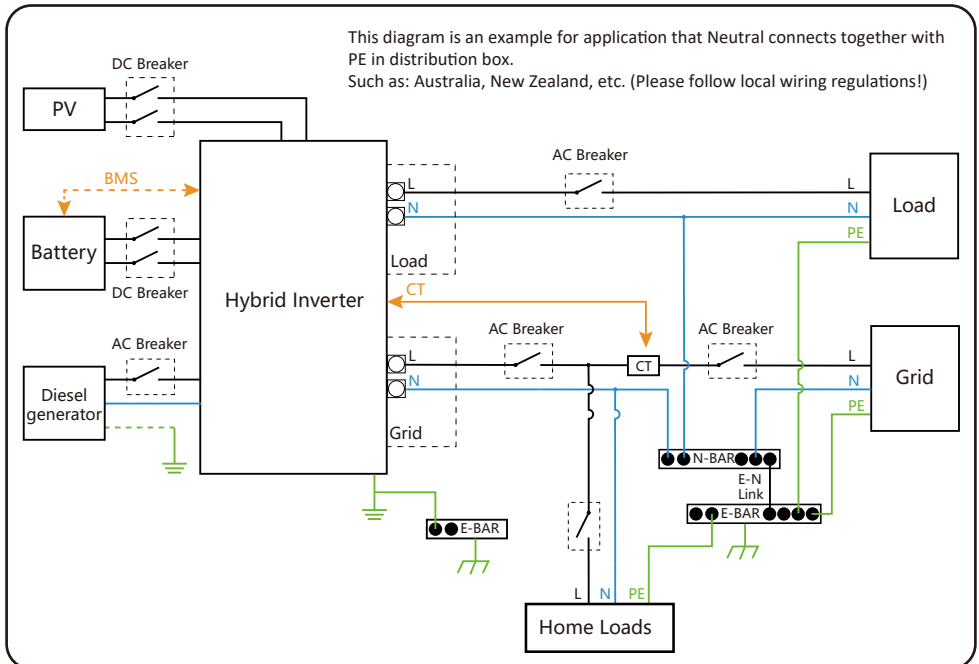
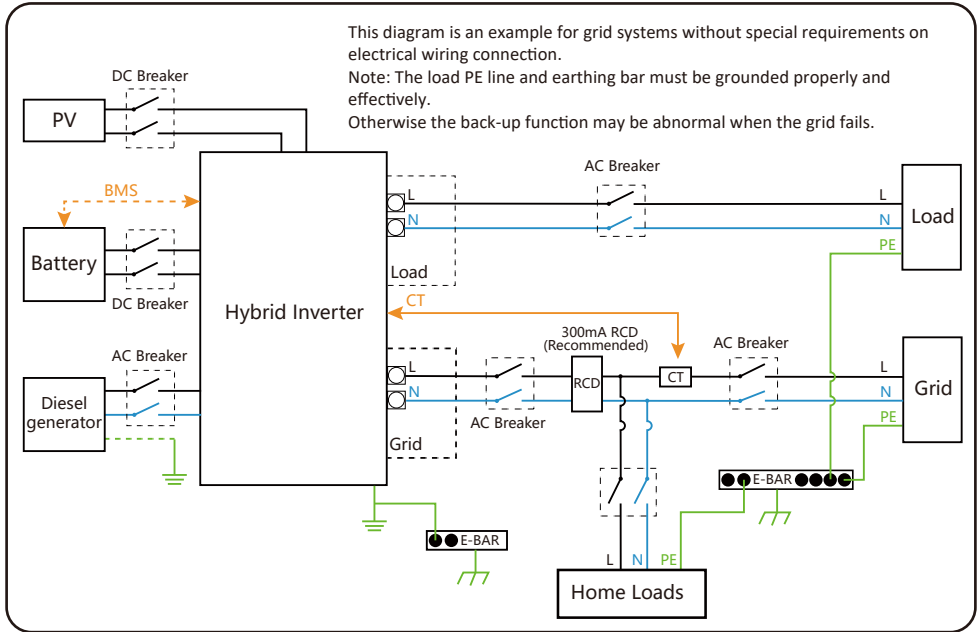

4.11 Single phase parallel connection diagram

Note: For the parallel system, please choose the "Zero export to CT" mode.

— CAN — L wire — N wire — PE wire

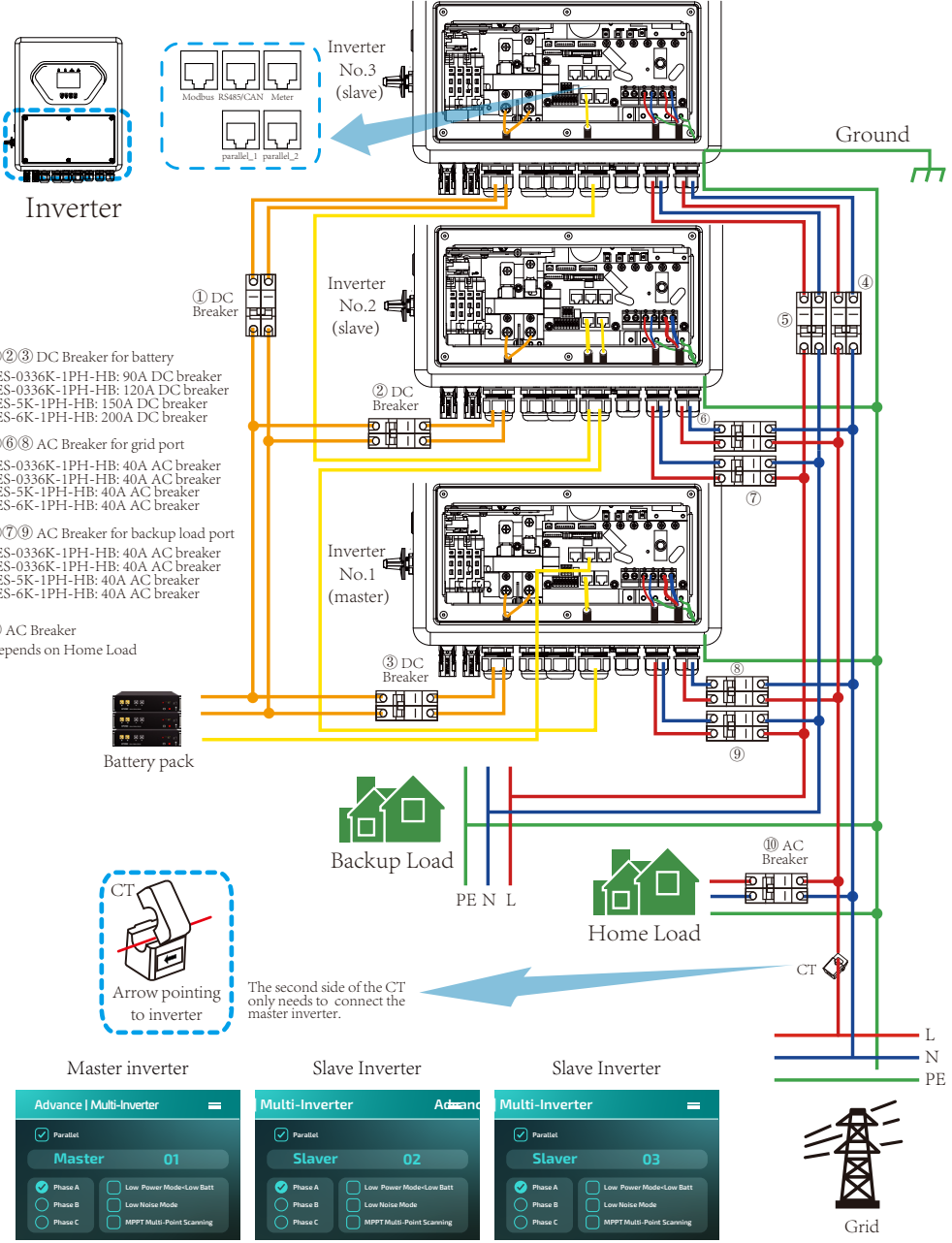

4.12 Three phase Parallel Inverter

①②③ DC Breaker for battery
 FES-0336K-1PH-HB: 90A DC breaker
 FES-0336K-1PH-HB: 120A DC breaker
 FES-5K-1PH-HB: 150A DC breaker
 FES-6K-1PH-HB: 200A DC breaker

⑤ AC Breaker for grid port
 FES-0336K-1PH-HB: 40A AC breaker
 FES-0336K-1PH-HB: 40A AC breaker
 FES-5K-1PH-HB: 40A AC breaker
 FES-6K-1PH-HB: 40A AC breaker

④ AC Breaker for backup load
 FES-0336K-1PH-HB: 40A AC breaker
 FES-0336K-1PH-HB: 40A AC breaker
 FES-5K-1PH-HB: 40A AC breaker
 FES-6K-1PH-HB: 40A AC breaker

⑥ AC Breaker
 Depends on Home Load

Note: For the parallel system, please choose the "Zero export to CT" mode.

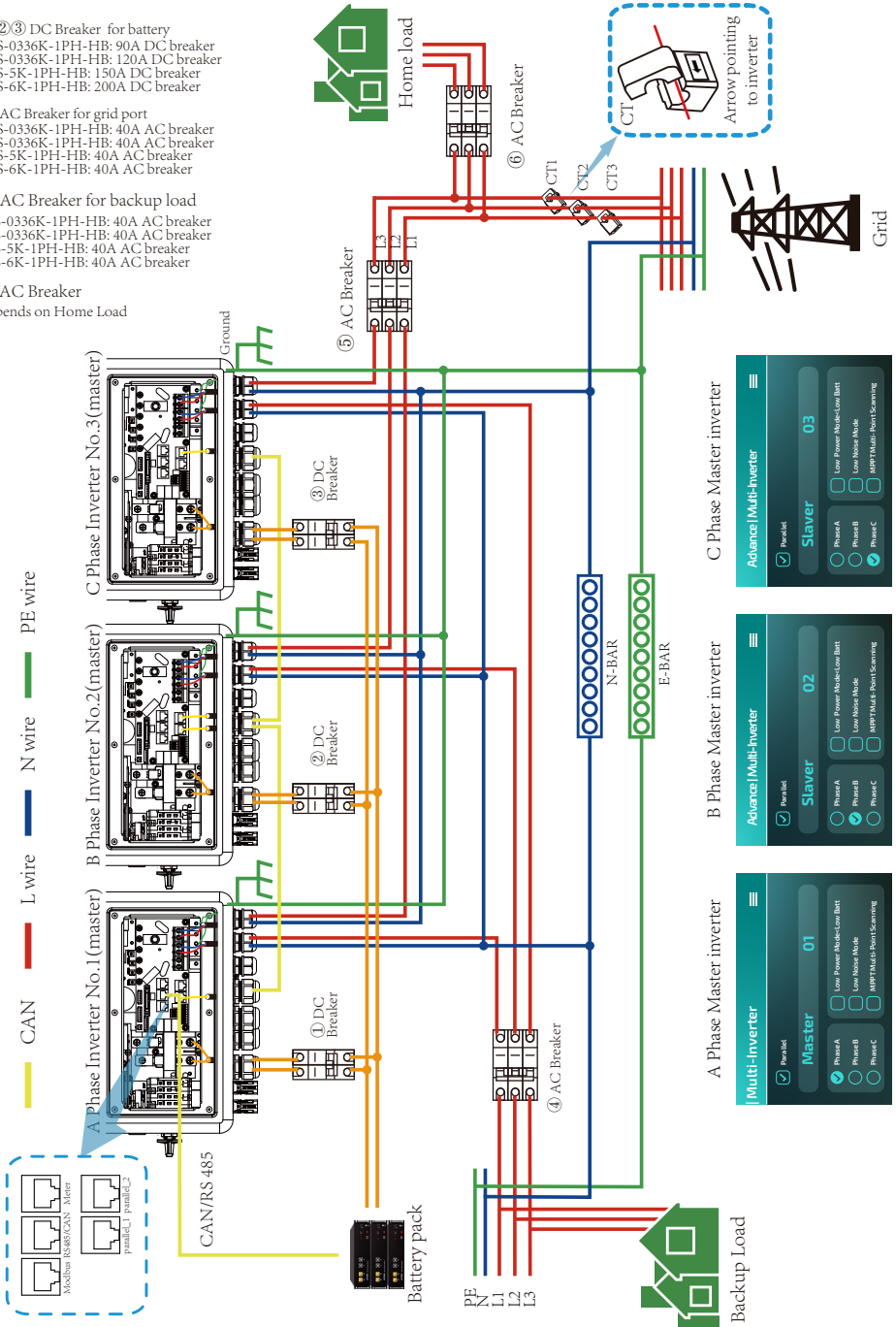

5. Operation

5.1 Power ON/OFF

Once the unit has been properly installed and the batteries are connected well, simply press On/Off button(located on the left side of the case) to turn on the unit. When system without battery connected, but connect with either PV or grid, and ON/OFF button is switched off, LCD will still light up(Display will show OFF), In this condition, when switch on ON/OFF button and select NO battery, system can still work.

5.2 Operation and Display Panel

The operation and display panel, shown in below chart, is on the front panel of the inverter. It includes four indicators, four function keys and a LCD display, indicating the operating status and input/output power information.

<i>LED Indicator</i>		<i>Messages</i>
DC	Green led solid light	PV Connection normal
AC	Green led solid light	Grid Connection normal
Normal	Green led solid light	Inverter operating normal
Alarm	Red led solid light	Malfunction or warning

Chart 5-1 LED indicators

<i>Function Key</i>	<i>Description</i>
Esc	To exit setting mode
Up	To go to previous selection
Down	To go to next selection
Enter	To confirm the selection

Chart 5-2 Function Buttons

6. LCD Display Icons

6.1 Main Screen

The LCD is touchscreen, below screen shows the overall information of the inverter.

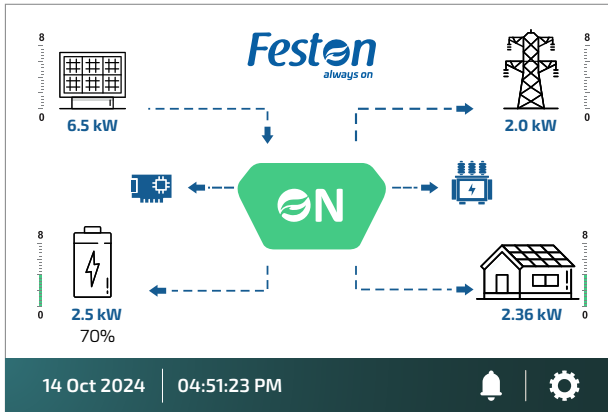

1. The icon in the center of the home screen indicates that the system is Normal operation. If it turns into "comm./FXX", it means the inverter has communication errors or other errors, the error message will display under this icon(FXX errors, detail error info can be viewed in the System Alarms menu).
2. At the bottom of the screen is the time.
3. SETTINGS Icon(Gear icon in the lower right corner), Press this set button, you can enter into the system setup screen which including Basic Setup, Grid Setup, Battery Setup, Li BMS, Fault Code, Aux Load, System Mode, Smart Link, Quick Control and Advance.
4. The main screen showing the info including Solar, Grid, Battery, Load, Generator and On-Grid Inverter.

- PV power and Load power always keep positive.
- Negative grid power means selling power to the grid, while positive means taking power from the grid.
- Negative battery power means charging, while positive battery power means discharging.

6.1.1 LCD operation flow chart

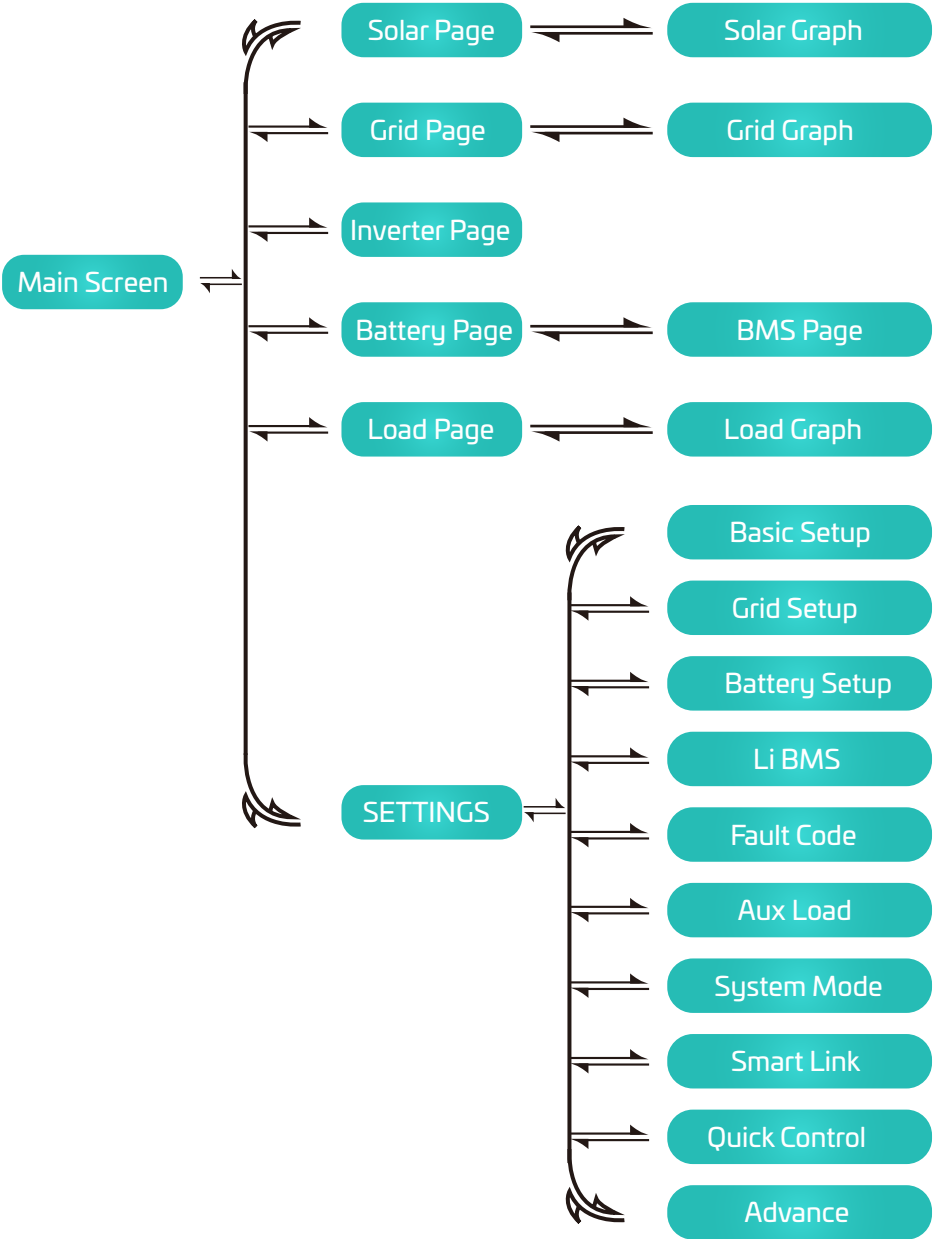

6.2 Detail page

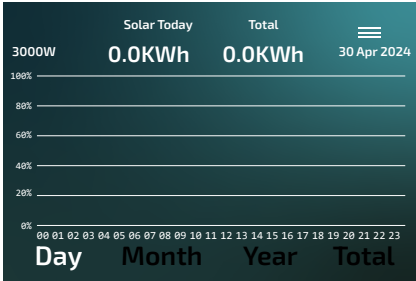

This is Solar Panel detail page.

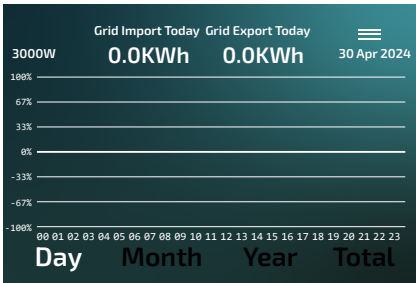

This is Grid detail page.

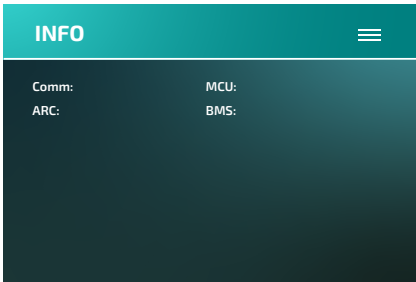

This is Inverter detail page.



This is Inverter detail page.

CT: Power detected by the external current sensors.
LD: Power detected using internal sensors on AC grid in/out breaker.

***DC:** mean DC-DC temperature.
***AC:** mean Heat-sink temperature.
*Note: Hidden by default, long press "Enter" to display.

6.3 Curve Page-Solar & Load & Grid

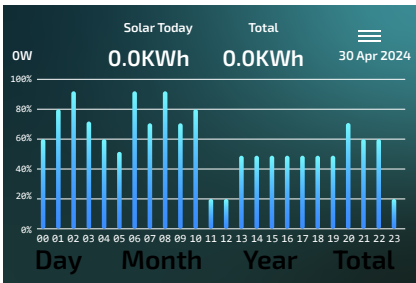
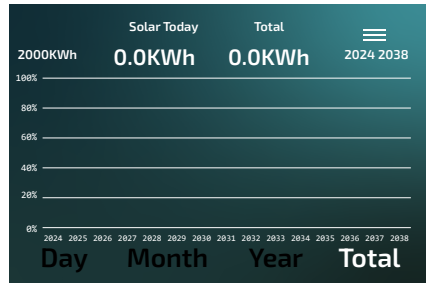
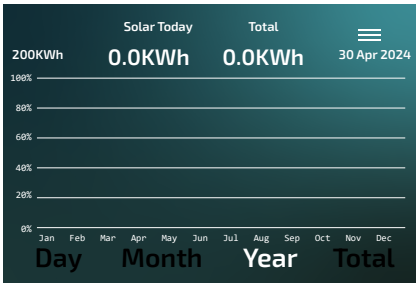
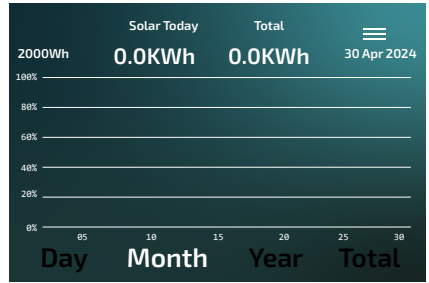
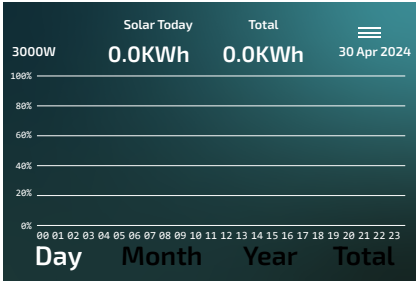

Solar power curve for daily, monthly, yearly and total can be roughly checked on the LCD, for more accuracy power generation, please check on the monitoring system. Click the buttons below the LCD screen to view the power curves of different time periods. The operation of checking the grid power and load power is similar to the above operation.

6.4 SETTINGS Menu

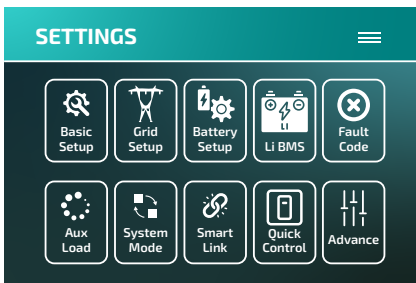

This is SETTINGS Menu page.



To avoid arbitrary changes or misoperation of key parameters, a preset password needs to be entered before making changes. The preset password is 7777.

6.5 Basic Setup Menu

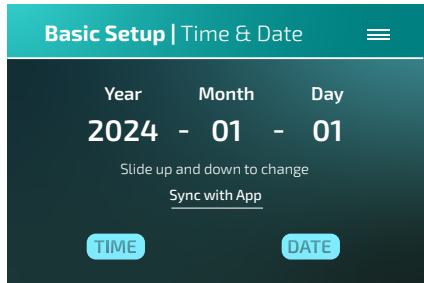
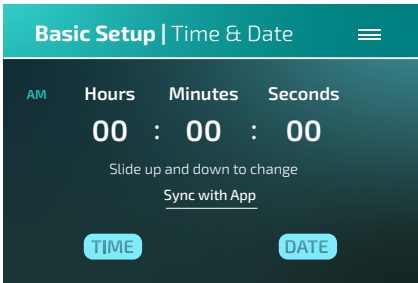
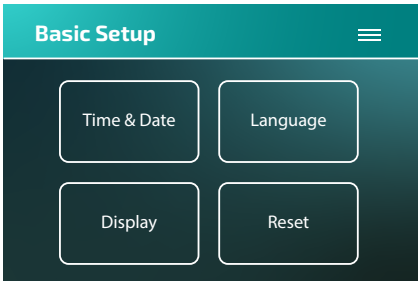

Swiping up and down on the screen can change the selected number to set the current time and date.
Sync with App: After enabling, when the inverter is communicating with the cloud platform via data logger, the inverter will keep the time in sync with cloud platform automatically.

Basic Setup | Language 

- English
- French
- Spanish
- Portuguse

On the "Language" page, you can set the display language of the LCD screen as needed.
Note: For current firmware version, only the English option is valid.

Basic Setup | Display 

Brightness

0%  100%

- LCD Auto Sleep Mode (5 mins)
- Beeper ON/OFF

Brightness: The screen brightness can be adjusted within the range of 0% to 100%
LCD Auto Sleep Mode(5 mins): When it's enabled, the LCD screen will be dim automatically after 5 minutes of non-operation.
Beeper ON/OFF: Used to turn on or off the beep sound in inverter's alarm status.

Basic Setup | Reset 

- Factory Reset
- Lock Out All Changes

Factory Reset: Reset all parameters of the inverter.
Lock Out All Changes: After being checked, programmable parameters will be locked to prevent them from being changed.

6.6 Grid Setup Menu

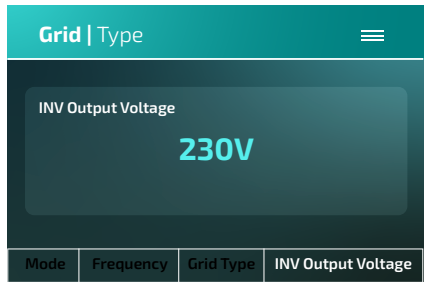
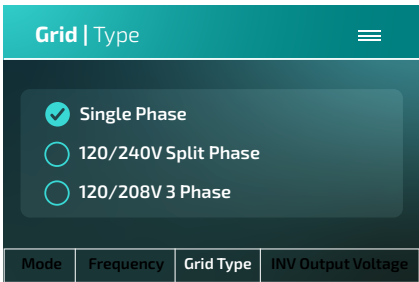
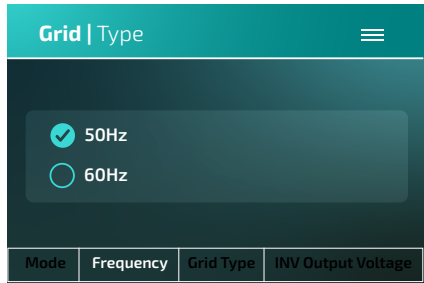
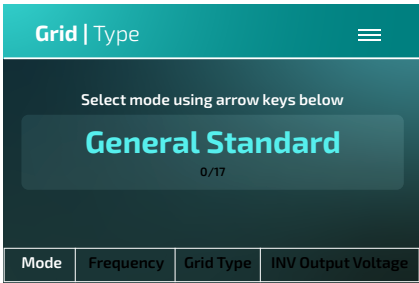
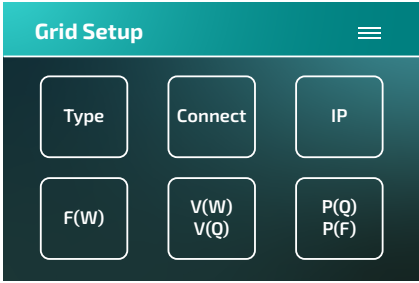

Mode: General Standard、UL1741 & IEEE1547、CPUC RULE21、SRD-UL-1741、CEI_0_21、EN50549_CZ、Australia_A、Australia_B、Australia_C、AS4777_NewZealand、VDE4105、OVE-Directive R25、EN50549_CZ_PPDS_L16A、NRS097、G98/G99、G98/G99_NI、ESB Networks(Ireland)、C10/11.
Please follow the local grid code and then choose the corresponding grid standard.

Grid Connect ☰		
Low Frequency	0.00 Hz	High Frequency
		0.00 Hz
Low Voltage	0.0 V	High Voltage
		0.0 V
Normal Ramp rate	00 S	
Normal Connect	Reconnect After Trip	Other

Normal Connect: The voltage and frequency range allowed for grid connection during the normal start-up process of the inverter.

Normal Ramp rate: The slope of the power climb of the inverter during normal startup process.

Grid Connect ☰		
Low Frequency	0.00 Hz	High Frequency
		0.00 Hz
Low Voltage	0.0 V	High Voltage
		0.0 V
Reconnect Ramp Rate	00 S	Reconnection Time
		0 S
Normal Connect	Reconnect After Trip	Other

Reconnect After Trip: When the inverter is reconnected to the grid after tripping, the allowed voltage and frequency range for grid connection.

Reconnection Time: The waiting time for the inverter reconnects to the grid when the grid voltage/frequency return to the allowed range after tripping.

Grid Connect ☰		
Power Factor		
0.000		
Normal Connect	Reconnect After Trip	Other

Power Factor: Power Factor is the ratio of active power to apparent power in the AC output circuit of the inverter.

Grid IP	
Over Voltage U (10min, running mean) 0.0 V	
HV1 0.00 V 0.00 S	LV1 0.00 V 0.00 S
HV2 0.00 V 0.00 S	LV2 0.00 V 0.00 S
HV3 0.00 V	LV3 0.00 V
Voltage	Frequency

Grid IP	
HF1 0.00 Hz 0.00 S	LF1 0.00 Hz 0.00 S
HF2 0.00 Hz 0.00 S	LF2 0.00 Hz 0.00 S
HF3 0.00 Hz	LF3 0.00 Hz
Voltage	Frequency

HV1: Level 1 overvoltage protection point;
HV2: Level 2 overvoltage protection point;
HV3: Level 3 overvoltage protection point.

LV1: Level 1 undervoltage protection point;
LV2: Level 2 undervoltage protection point;
LV3: Level 3 undervoltage protection point.

HF1: Level 1 over frequency protection point;
HF2: Level 2 over frequency protection point;
HF3: Level 3 over frequency protection point.

LF1: Level 1 under frequency protection point;
LF2: Level 2 under frequency protection point;
LF3: Level 3 under frequency protection point.

0.00 S—Trip time.

Grid F(W)	
<input type="checkbox"/> F(W)	Start Delay F
Start Frequency F 0.00 HZ	0.00 s
Stop Frequency F 0.00 HZ	Stop Delay F 0.00 s
	Droop F 0%PE/Hz
Over Frequency	Under Frequency

Grid F(W)	
<input type="checkbox"/> F(W)	Start Delay F
Start Frequency F 0.00 HZ	0.00 s
Stop Frequency F 0.00 HZ	Stop Delay F 0.00 s
	Droop F 0%PE/Hz
Over Frequency	Under Frequency

F(W): It's used to adjust the output active power of inverter according to the frequency of grid.

Droop F: percentage of nominal power per Hz

For example, "Start freq F=50.2Hz, Stop freq F=51.5, Droop F=40%PE/Hz" when the grid frequency reaches 51.2Hz, the inverter will decrease its active power at rate of 40% per Hz. Then when frequency of grid is less than 50.2Hz, the inverter will stop decreasing output power.

For the detailed setup values, please follow the local grid code.

Grid V(W) V(Q) <input type="checkbox"/> v(w) ☰			
V1	0.0 %Un	P1	0 %
V2	0.0 %Un	P2	0 %
V3	0.0 %Un	P3	0 %
V4	0.0 %Un	P4	0 %
V(W)		V(Q)	

Grid V(W) V(Q) <input type="checkbox"/> v(Q) ☰				
Lock-in/Pn 0 %	V1	0.0 %Un	V2	0.0 %Un
	V3	0.0 %Un	V4	0.0 %Un
Lock-out/Pn 0 %	Q1	0.0 %	Q2	0.0 %
	Q3	0.0 %	Q4	0.0 %
	V(W)		V(Q)	

V(W): It is used to adjust the inverter's active power according to the set grid voltage.

For example: V2=110%, P2=20%. When the grid voltage reaches the 110% times of rated grid voltage, inverter output power will reduce its active output power to 20% rated power.

V(Q): It is used to adjust the inverter's reactive power according to the set grid voltage.

These two functions are used to adjust inverter's output power (active power and reactive power) when grid voltage changes.

Lock-in/Pn: When the output active power of the inverter drops to the preset lower threshold (such as 5% rated power), the inverter will automatically activate the V (Q) reactive power regulation function.

Lock-out/Pn: When the output active power of the inverter rises to the preset upper threshold (such as 90% rated power), the inverter will automatically switch off the V (Q) reactive power regulation function. When the grid voltage drops to 90% of the rated grid voltage of the inverter, the inverter can output up to 44% (the ratio to the rated apparent power) of reactive power, helping to stabilize the grid voltage at the grid connection point.

Grid P(Q) P(F) <input type="checkbox"/> Q(P) ☰			
P1	0 %	Q1	0 %
P2	0 %	Q2	0 %
P3	0 %	Q3	0 %
P4	0 %	Q4	0 %
P(Q)		P(F)	

Grid P(Q) P(F) <input type="checkbox"/> PF(P) ☰				
Lock-in/Pn 0 %	P1	0 %	P2	0 %
	P3	0 %	P4	0 %
Lock-out/Pn 0 %	F1	0.000	F2	0.000
	F3	0.000	F4	0.000
	P(Q)		P(F)	

Q(P): It is used to adjust the inverter's reactive power according to the set active power.

PF(P): It is used to adjust the inverter's PF according to the set active power.

For the detailed setup values, please follow the local grid code.

Lock-in/Pn: When the output ratio of the active power of the inverter drops below this threshold, the PF(P) regulation mechanism will be activated and take effect.

Lock-out/Pn: When the output ratio of the active power of the inverter reaches this threshold, the PF(P) regulation mechanism will be switched off.

Note: only when the grid voltage is equal to or higher than 1.05 times of rated grid voltage, then the PF(P) mode will take effect.

6.7 Battery Setup Menu

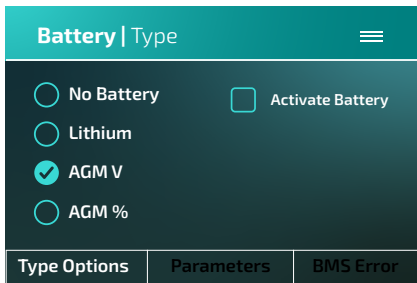
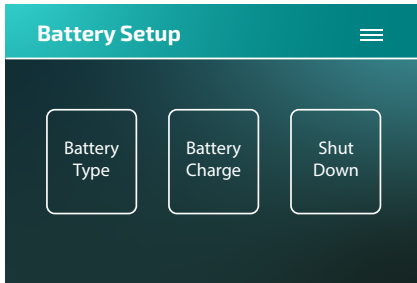

No Battery: tick this item if no battery is connected to the system.
AGM V: Use Battery Voltage(V) for all the settings..
AGM %: Use the percentage of battery energy(%) for all settings.
Activate battery: This feature will help recover a battery that is over discharged by slowly charging from the solar array or grid.

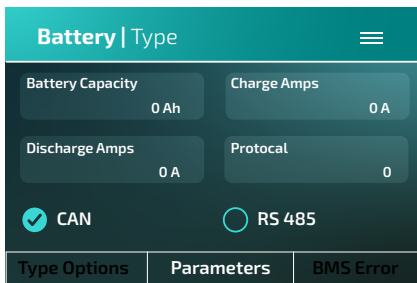

Battery Capacity: When set the "Type Options" as "AGM %", battery capacity can be used to calibrate battery SOC.
Charge/Discharge Amps: Max battery charge/discharge current(0-70A for 3KW model, 0-90A for 3.6KW model, 0-120A for 5KW model, 0-135A for 6KW model).
 For AGM and Flooded, we recommend setting the max A charge/discharge current as no more than battery capacity x 20%.
 . For Lithium, we recommend Ah battery size x 50% = Charge/Discharge amps.
 . For Gel, follow manufacturer' s instructions.

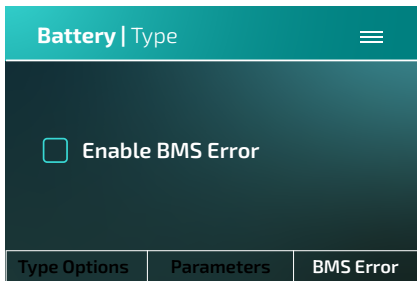

Enable BMS Error: When it is enabled, if the battery BMS failed to communicate with inverter, the inverter will stop working and report fault.

Battery Charge		☰
<input type="checkbox"/> Gen Charge	Start	0.0 V
<input type="checkbox"/> Gen Signal	A	0 A
<input type="checkbox"/> Grid Charge	Start	0.0 V
<input type="checkbox"/> Grid Signal	A	0 A
Gen/Grid		Parameters

This is Battery Setup page.

Gen Charge: Use the AC input power of GEN port to charge the battery.

Gen Signal: When conditions are sufficient, the inverter will close or open the normally open relay used to control the start and stop of the generator.

Start: When battery SOC drop to this set value, the inverter will autostart the connected generator to charge the battery.

A: The maximum charging current allowed when only use AC power from GEN port to charge the battery.

This is Grid Charge, you need select.

Grid Charge: It's allowed to absorb AC power from the grid port to charge the battery.

Grid Signal: When a generator is connected to the grid port of hybrid inverter, this "Grid signal" can be used to control the dry contact to start or stop the generator.

Start: No use, Just for customization.

A: The maximum charging current allowed when only use AC power from GRID port to charge the battery.

Battery Charge		☰
Float V 0.0 V	Absorption V 0.0 V	
Equalization V 0.0 V	Equalization Days 0 days	
Equalization Hours 0.0 hours		
Gen/Grid		Parameters

Three stage charging strategy for lead-acid and incompatible lithium battery.

Battery Shut Down		☰
Shut Down 0.0 V	Low Battery 0.0 V	
Restart 0.0 V		

Shut Down: Be valid in Off-grid mode, when battery SOC/ voltage drop to this value, then the DC/AC inverter module of this inverter will be shut down and the solar power can only be used to charge the battery.

Low Battery: Be valid in On-grid mode, when the "Grid charge" has been checked and the set target battery SOC/ voltage on "TOU" page isn't less than the "Low Battery" value, the battery SOC/voltage will remain above the value of "Low Battery".

Restart: Be valid in Off-grid mode, after the DC/AC inverter module of this inverter is shut down, the PV power can only be used to charge the battery. When the battery SOC/ Voltage has returned to this "Restart" value, the DC/AC inverter module will restart to output AC power.

6.8 Li BMS Menu

Li BMS	
Battery Voltage	0.00 V
Battery Current	0A
Battery Temperature	-00.0C
Total SOC	0%
Total SOH	0%
Battery Charge Voltage	0.0V
Charge Current Limit	0A
Discharge Current Limit	0A
Alarms: 0x0000 0x0000	

This is Battery detail page.

6.9 Fault Code Menu

Fault Code	
F29 Parallel_CANbus_Fault	2025-07-22 09:55
F41 Parallel_System_Stop	2025-07-22 09:51
F56 Dc_VoltLow_Fault	2025-07-22 09:20

Alarms Code ID:2405042782 Occured

This is Fault Code detail page.
Please refer to the corresponding content in Chapter 7-1 for troubleshooting solutions.

6.10 Aux Load Setup Menu

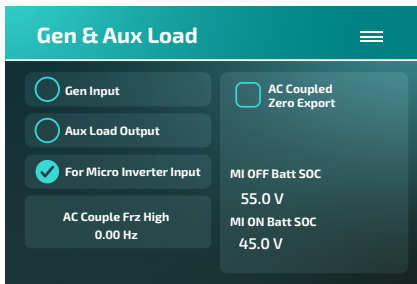
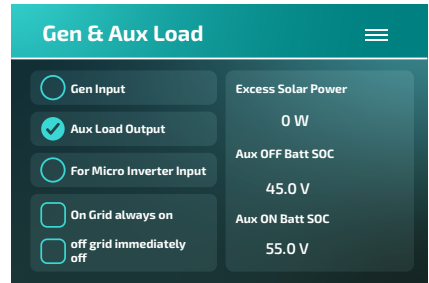
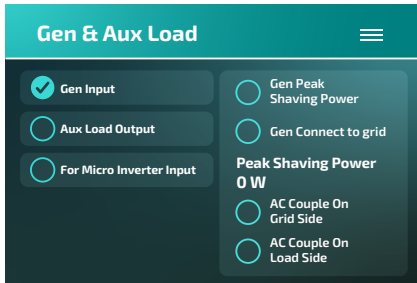

Gen Input: allowed Max. power from diesel generator.

Gen Peak Shaving Power: Limit the maximum output power of the generator to the set rated power on "GEN PORT USE" page, the rest of power consumption will be provided by PV and battery to ensure that the generator will not overload.

Gen Connect to grid: connect the diesel generator to the grid input port.

AC Couple On Grid Side: Connecting the output of on-grid inverter at the grid port of the hybrid inverter.

AC Couple On Load Side: Connecting the output of on-grid inverter at the load port of the hybrid inverter. In this situation, the hybrid inverter will not able to show the load power correctly.

Aux Load Output: Use the GEN port as an AC output port, and the load connected to this port can be controlled on/off by the hybrid inverter.

- **Aux OFF Batt SOC:** Battery SOC at which the Smart load will switch off.
- **Aux ON Batt SOC:** Battery SOC at which the Smart load will switch on. Besides, the PV input power should exceed the setting value (Power) simultaneously and then the Smart load will switch on.
- **On Grid always on:** When click "on Grid always on" the smart load will switch on when the grid is present.
- **off grid immediately off:** The smart load will stop working immediately when the grid is disconnected if this item is active.

For Micro Inverter Input: To use the Generator input port as a AC input port of micro-inverter or other on-grid inverter.

- **MI OFF Batt SOC:** When the battery SOC or voltage rise to this set value and the hybrid inverter is operating in off-grid mode, the frequency of GEN port of hybrid inverter will be raised to 'AC Couple Frz High' to make the Grid-tied inverter trip. It's invalid in on-grid mode.
- **MI ON Batt SOC:** When the battery SOC or voltage drops below this set value, the relay on GEN port of hybrid inverter will be closed, then the Grid-Tied inverter will generate power and feed into hybrid inverter.

AC Couple Frz High: If choosing "Micro Inv input", as the battery SOC reaches gradually setting value (OFF), During the process, the microinverter output power will decrease linear. When the battery SOC equals to the setting value (OFF), the system frequency will become the setting value (AC couple Frz high) and the microinverter or on-grid inverter will trip from hybrid inverter.

• **Note:** Micro Inv Input OFF and On is valid for some certain FW version only.

6.11 System Mode Setup Menu

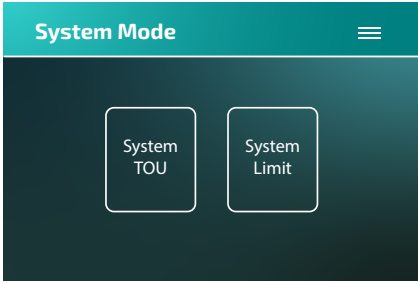

System | TOU

Use Timer

Time Start	Time End	Power	SOC/V	Grid	Gen
01:00	05:00	4000	49.0V	<input type="checkbox"/>	<input type="checkbox"/>
05:00	09:00	4000	49.0V	<input type="checkbox"/>	<input type="checkbox"/>
09:00	13:00	4000	49.0V	<input type="checkbox"/>	<input type="checkbox"/>
13:00	17:00	4000	49.0V	<input type="checkbox"/>	<input type="checkbox"/>
17:00	21:00	4000	49.0V	<input type="checkbox"/>	<input type="checkbox"/>
21:00	01:00	4000	49.0V	<input type="checkbox"/>	<input type="checkbox"/>

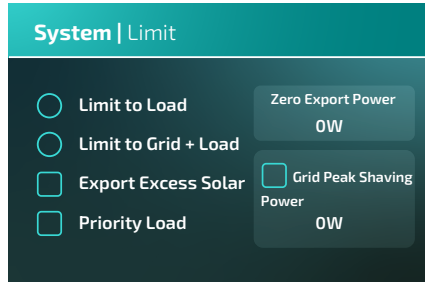

Use Timer: it is used to program when to use grid or generator to charge the battery, and when to discharge the battery to power the load. Only tick "Time Of Use" then the follow items (Grid, charge, time, power etc.) will take effect.

Time: real time, range of 01:00-24:00.

Power: Max. discharge power of battery allowed.

SOC/V The target value of battery voltage or SOC during the current time period. If the actual SOC or voltage of the battery is lower than this target value, the battery needs to be charged. If there is a energy source like solar power or grid, the battery will be charged; If the actual SOC or voltage of the battery is higher than this target value, the battery can discharge, and when the solar power is not enough to power the load or the "Selling First" is enabled, the battery will discharge.

Grid: utilize grid to charge the battery in a time period.

Gen: utilize diesel generator to charge the battery in a time period.

Limit to Load: Hybrid inverter will only provide power to the backup load connected. The hybrid inverter will neither provide power to the home load nor sell power to grid, if the "solar sell" behind is not enabled. The built-in CT will detect current flowing back to the grid, if there is, the inverter will reduce the generate power to only power the backup loads, smart loads and charge the battery.

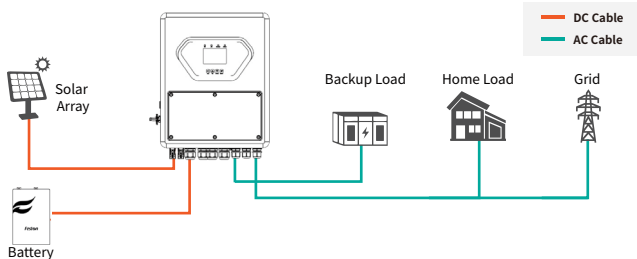

Limit to Grid + Load: Hybrid inverter will not only provide power to the backup load connected but also give power to the home load connected. If PV power and battery power is insufficient, it will take grid energy as supplement. The hybrid inverter will not sell power to grid, if the "solar sell" behind is not enabled. In this mode, a external CT or smart meter must be installed. As to the installation method of the CT or smart meter, please refer to the chapter 3.7 of this manual. The external CT or smart meter will detect the current flowing back to the grid, if there is, the inverter will reduce generate power to prevent selling power to grid.

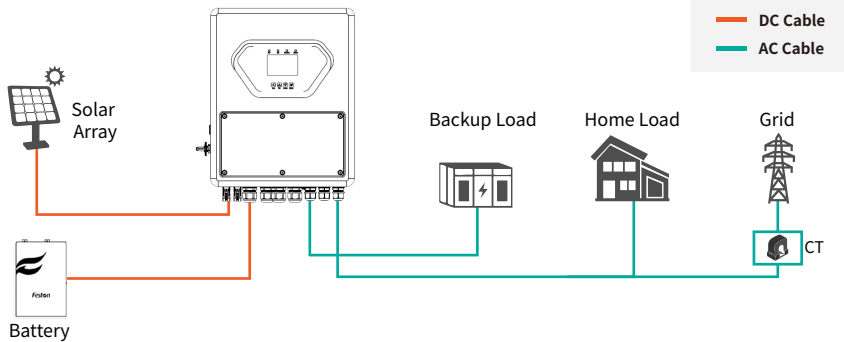

Export Excess Solar: "Export Excess Solar" is for Limit to Load or Limit to Grid + Load: when this item is active, the PV energy will first power the loads or charge the battery, then the surplus PV energy can be sold back to grid.

Priority Load: PV power is firstly used to power the load and then used to charge the battery. If PV power is insufficient, grid will make supplement for battery and load simultaneously.

Zero Export Power: This parameter will ensure the zero-export by taking from the grid some small amount of energy that has been set with this value. It is recommended to set it as 20-100W to ensure the hybrid inverter won't feed power to grid.

Grid Peak Shaving: When it is active, grid output power will be limited within the set value. If the grid peak-shaving power plus PV power plus battery power cannot meet the power consumption of the load, the grid peak-shaving will be invalid, and the power taken from the grid can exceed this set value.

6.12 Quick Control Setup Menu

Quick Control	☰
<input type="checkbox"/> Force Generator	
<input type="checkbox"/> Beeper Override	
<input type="checkbox"/> LCD Auto Sleep Mode (5 mins)	
<input type="checkbox"/> Allow Remote Control	

Force Generator: When the generator is connected, it is forced to start the generator without meeting other conditions.

Beeper Override: Used to turn on or off the beep sound in inverter's alarm status.

LCD Auto Sleep Mode (5 mins): When it's enabled, the LCD screen will be dim automatically after 5 minutes of non-operation.

Allow Remote Control: Whether to enter the "Remote Control" mode, after entering the "Remote control" mode, EMS and other upper computers can read and write specific registers of the inverter.

6.13 Advance Setup Menu

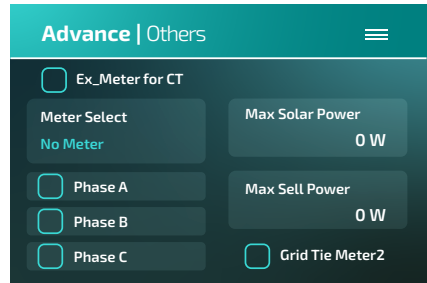
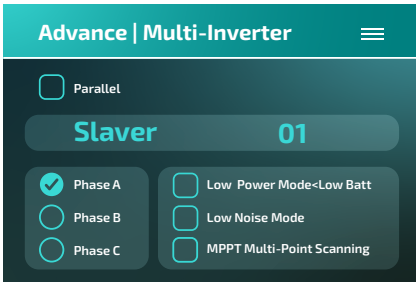
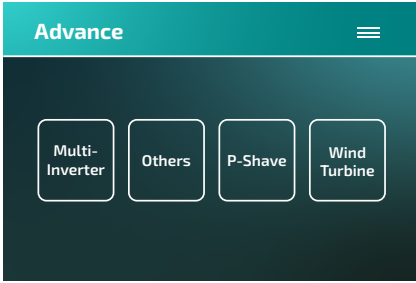

Parallel: Enable this function when several same model hybrid inverters are connecting in parallel.

Master: Select any hybrid inverter in the parallel system as the master inverter, and the master inverter needs to manage the working mode of the parallel system.

Slaver: Set the other inverters managed by the master inverter as slave inverter.

Phase A/B/C: When forming a 3-phase system in parallel, it is necessary to set which phase of the three-phase system this inverter belongs to.

Low Power Mode<Low Batt: When it's selected and battery SOC is less than "Low Bat" value, the self-consumption power of inverter will supply by grid and battery simultaneously. If unselected, the self-consumption power of inverter will supply by battery.

Low Noise Mode: In this mode, the sound emitted by the inverter during operation will be smaller.

MPPT Multi-Point Scanning: The inverter will check whether the PV is working on its Max. power point. If not, then it will adjust the voltage of MPPT to ensure the PV operates at the Max. power point.

Ex_Meter for CT: Check this function when using "Zero export to CT" mode and use external smart meter replace the CTs.

Meter Select: select the corresponding meter type according to the meter installed in the system.

Phase A/B/C: When this inverter is installed in three phase grid and measured by three phase smart meter, click corresponding phase which this hybrid inverter is connected.

For example, when the hybrid inverter connects to A phase of grid, please click A Phase here.

Grid Tie Meter2: When there's a on-grid inverter AC couple at the grid or load side of hybrid inverter and there's a meter installed for the on-grid inverter, then the hybrid inverter LCD will show the on-grid inverter output power on its PV icon. Please make sure the meter can communicate with the hybrid inverter successfully.

Max Sell Power: Maximum power allowed to flow to grid.

Max Solar Power: The maximum DC input power allowed.

Advance | P-Shave

- System Selfcheck
- Signal Island Mode
- DRM
- Solar Arc Fault ON
- Clear Arc_Fault

Backup Delay: 0 ms

ATS: OFF

CT Ratio: 0

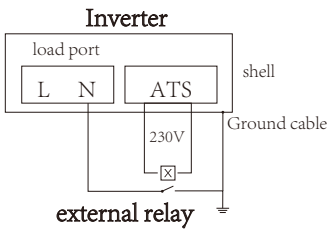

System Selfcheck: Disable. this is only for factory.

Signal Island Mode: When "Signal Island Mode" is checked and the inverter operates in on-grid mode, the ATS port voltage will be 0. Else, in off-grid mode, the ATS port voltage will output 230Vac voltage. With this feature and external NO type relay, it can realize N and PE disconnection or bond.

More details, please refer to left side picture.

DRM: Demand response mode, receive external commands for scheduling active power and reactive power.

Solar Arc Fault ON: This feature is optional. After enabling this function, the inverter will detect whether there is a arcing fault on the PV side. If arcing occurs, the inverter will report a fault and stop outputting power.

Clear Arc_Fault: After the arc fault on the PV side is eliminated, enabling this function can eliminate the arc fault alarm of the inverter and restore normal operation of the inverter.

Backup Delay: When the grid cuts off, the inverter will output power after this set time.
For example, backup delay: 3ms. the inverter will give output power after 3ms when the grid cuts off.

ATS: It is related to the output voltage of the ATS port, and it is recommended to leave it unselected.

CT Ratio: When using an external CT alone, this parameter needs to be set. When using an external meter, it does not need to be set.

Advance | Wind Turbine

- DC1 for Wind Turbine
- DC2 for Wind Turbine

V1	0 V	0.0 A	V7	0 V	0.0 A
V2	0 V	0.0 A	V8	0 V	0.0 A
V3	0 V	0.0 A	V9	0 V	0.0 A
V4	0 V	0.0 A	V10	0 V	0.0 A
V5	0 V	0.0 A	V11	0 V	0.0 A
V6	0 V	0.0 A	V12	0 V	0.0 A

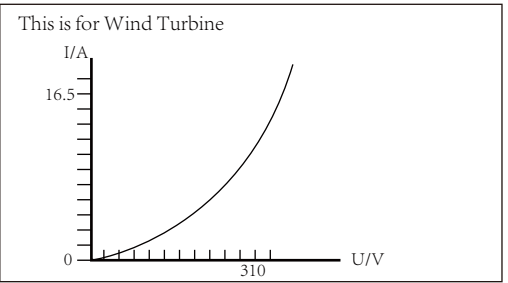

7. Mode

Mode I: Basic

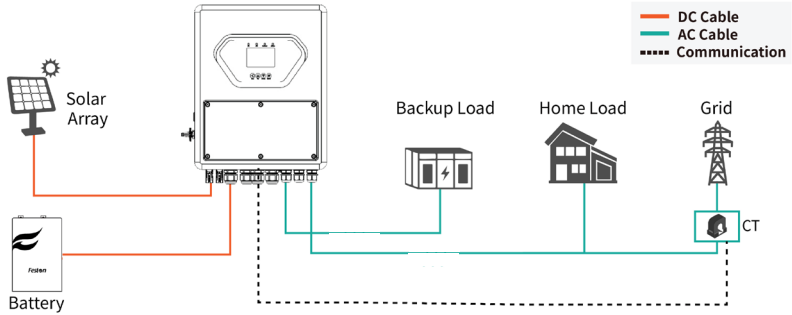

Mode II: With Generator

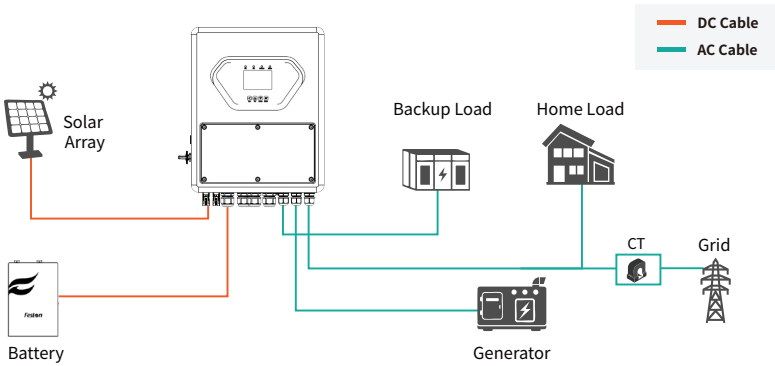

Mode III: With Smart-Load

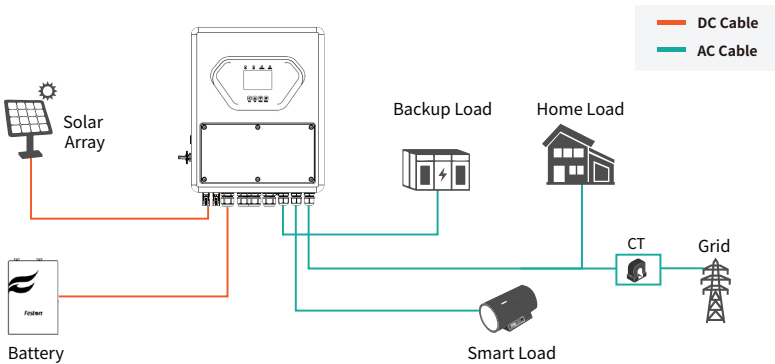

Mode IV: AC Couple

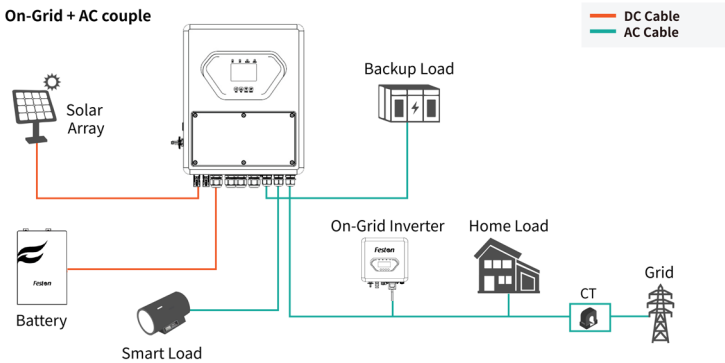
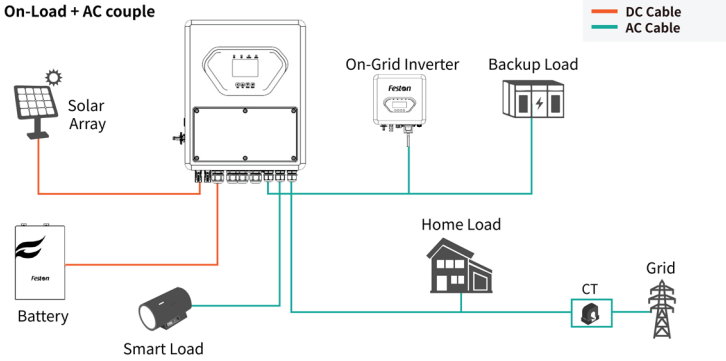
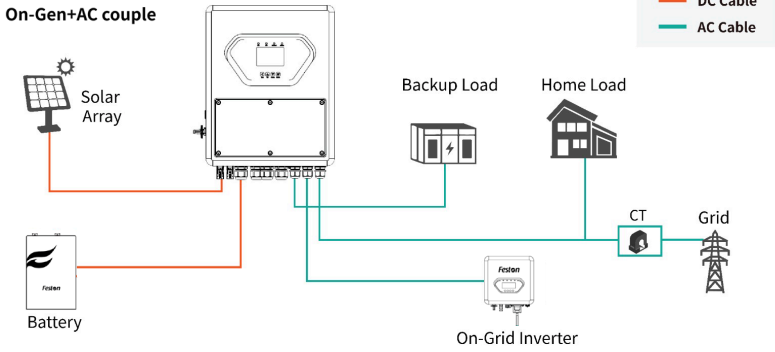

The 1st priority power of the system is always the PV power, then 2nd and 3rd priority power will be the battery bank or grid according to the settings. The last power backup will be the Generator if it is available.

8. Fault information and processing

The energy storage inverter is designed according to the grid-connected operation standard and meets the safety requirements and electromagnetic compatibility requirements. Before leaving the factory, the inverter undergoes several rigorous tests to ensure that the inverter can operate reliably.



If any of the fault messages listed in Table 8-1 appear on your inverter and the fault has not been removed after restarting, please contact your local dealer or service center. You need to have the following information ready.

1. Inverter serial number;
2. Distributor or service center of the inverter ;
3. On-grid power generation date;
4. The problem description (including the fault code and indicator status displayed on the LCD) is as detailed as possible.
5. Your contact information. In order to give you a clearer understanding of the inverter's fault information, we will list all possible fault codes and their descriptions when the inverter is not working properly.

Error code	Description	Solutions
F08	GFDI _Relay_Failure	<ol style="list-style-type: none"> 1. When inverter is in Split phase(120/240Vac) or three-phase system (120/208Vac) system, the backup load port N line needs to connect ground; 2. If the fault still exists, please contact us for help.
F13	Working mode change	<ol style="list-style-type: none"> 1. When the grid type and frequency changed it will report F13; 2. When the battery mode was changed to "No battery" mode, it will report F13; 3. For some old FW version, it will report F13 when the system work mode changed; 4. Generally, it will disappear automatically when shows F13; 5. If still same, and turn off the DC switch and AC switch and wait for one minute and then turn on the DC/AC switch; 6. Seek help from us, if can not go back to normal state.
F18	AC over current fault of hardware	<p>AC side over current fault</p> <ol style="list-style-type: none"> 1. Please check whether the backup load power and common load power are within the range; 2. Restart and check whether it is in normal; 3. Seek help from us, if can not go back to normal state.
F20	DC over current fault of the hardware	<p>DC side over current fault</p> <ol style="list-style-type: none"> 1. Check PV module connect and battery connect; 2. When in the off-grid mode, the inverter startup with big power load, it may report F20. Please reduce the load power connected; 3. Turn off the DC switch and AC switch and then wait one minute, then turn on the DC/AC switch again; 4. Seek help from us, if can not go back to normal state.
F22	Tz_EmergStop_Fault	Please contact your installer for help.
F23	AC leakage current is transient over current	<p>Leakage current fault</p> <ol style="list-style-type: none"> 1. Check PV side cable ground connection. 2. Restart the system 2~3 times. 3. If the fault still exists, please contact us for help.

Error code	Description	Solutions
F24	DC insulation impedance failure	PV isolation resistance is too low 1. Check the connection of PV panels and inverter is firmly and correctly; 2. Check whether the PE cable of inverter is connected to ground; 3. Seek help from us, if can not go back to normal state.
F26	The DC busbar is unbalanced	1. Please wait for a while and check whether it is normal; 2. When the hybrid in split phase mode, and the load of L1 and load of L2 is big different, it will report the F26. 3. Restart the system 2~3 times. 4. Seek help from us, if can not go back to normal state.
F29	Parallel CANBus fault	1. When in parallel mode, check the parallel communication cable connection and hybrid inverter communication address setting; 2. During the parallel system startup period, inverters will report F29. when all inverters are in ON status, it will disappear automatically; 3. If the fault still exists, please contact us for help.
F34	AC Overcurrent fault	1. Check the backup load connected, make sure it is in allowed power range; 2. If the fault still exists, please contact us for help.
F35	No AC grid	No Utility 1. Please confirm grid is lost or not; 2. Check the grid connection is good or not; 3. Check the switch between inverter and grid is on or not; 4. Seek help from us, if can not go back to normal state.
F41	Parallel system stop	1. Check the hybrid inverter working status. If there's 1 pcs hybrid inverter is in OFF status, the other hybrid inverters may report F41 fault in parallel system. 2. If the fault still exists, please contact us for help.
F42	AC line low voltage	Grid voltage fault 1. Check the AC voltage is in the range of standard voltage in specification; 2. Check whether grid AC cables are firmly and correctly connected; 3. Seek help from us, if can not go back to normal state.
F47	AC over frequency	Grid frequency out of range 1. Check the frequency is in the range of specification or not; 2. Check whether AC cables are firmly and correctly connected; 3. Seek help from us, if can not go back to normal state.
F48	AC lower frequency	Grid frequency out of range 1. Check the frequency is in the range of specification or not; 2. Check whether AC cables are firmly and correctly connected; 3. Seek help from us, if can not go back to normal state.
F56	DC busbar voltage is too low	Battery voltage low 1. Check whether battery voltage is too low; 2. If the battery voltage is too low, using PV or grid to charge the battery; 3. Seek help from us, if can not go back to normal state.

Error code	Description	Solutions
F58	BMS communication fault	<ol style="list-style-type: none"> 1. it tells the communication between hybrid inverter and battery BMS disconnected when "BMS_Err-Stop" is active; 2. if don't want to see this happen, you can disable "BMS_Err-Stop" item on the LCD; 3. If the fault still exists, please contact us for help.
F63	ARC fault	<ol style="list-style-type: none"> 1. ARC fault detection is only for US market; 2. Check PV module cable connection and clear the fault; 3. Seek help from us, if can not go back to normal state.
F64	Heat sink high temperature failure	<p>Heat sink temperature is too high</p> <ol style="list-style-type: none"> 1. Check whether the work environment temperature is too high; 2. Turn off the inverter for 10mins and restart; 3. Seek help from us, if can not go back to normal state.

Chart 8-1 Fault information

Under the guidance of our company, customers return our products so that our company can provide service of maintenance or replacement of products of the same value. Customers need to pay the necessary freight and other related costs. Any replacement or repair of the product will cover the remaining warranty period of the product. If any part of the product or product is replaced by the company itself during the warranty period, all rights and interests of the replacement product or component belong to the company.

Factory warranty does not include damage due to the following reasons:

- Damage during transportation of equipment ;
- Damage caused by incorrect installation or commissioning ;
- Damage caused by failure to comply with operation instructions, installation instructions or maintenance instructions ;
- Damage caused by attempts to modify, alter or repair products ;
- Damage caused by incorrect use or operation ;
- Damage caused by insufficient ventilation of equipment ;
- Damage caused by failure to comply with applicable safety standards or regulations ;
- Damage caused by natural disasters or force majeure (e.g. floods, lightning, overvoltage, storms, fires, etc.)

In addition, normal wear or any other failure will not affect the basic operation of the product. Any external scratches, stains or natural mechanical wear does not represent a defect in the product.

9. Limitation of Liability

In addition to the product warranty described above, the state and local laws and regulations provide financial compensation for the product's power connection (including violation of implied terms and warranties). The company hereby declares that the terms and conditions of the product and the policy cannot and can only legally exclude all liability within a limited scope.

10. Appendix I

Definition of RJ45 Port Pin for RS485.

No.	RS485/CAN Pin
1	485_B
2	485_A
3	GND_485
4	CAN-H
5	CAN-L
6	GND_485
7	485_A
8	485_B

RS485/CAN Port

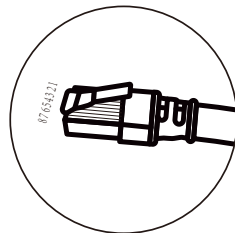
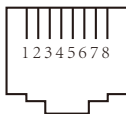

Definition of RJ45 Port Pin for Meter.

This port is used to communicate with energy meter.

No.	Meter Pin
1	485-B
2	485-A
3	
4	485-B
5	485-A
6	GND
7	485-A
8	485-B

Meter port

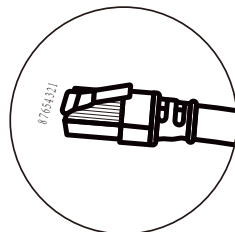

Definition of RJ45 Port Pin of "Modbus port" for remotely monitoring.

No.	Modbus Pin
1	SUNSPE-485_B
2	SUNSPE-485_A
3	GND_SUNSPE-485
4	
5	
6	GND_SUNSPE-485
7	SUNSPE-485_A
8	SUNSPE-485_B

Modbus Port

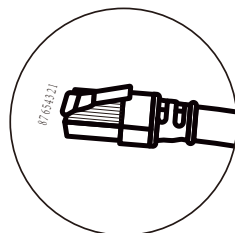
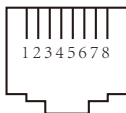

This model of inverter has two types of logger interfaces, DB9 and USB. Please refer to the actual inverter received for the actual interface type.

RS232

No.	RS232
1	
2	TX
3	RX
4	
5	D-GND
6	
7	
8	
9	12Vdc

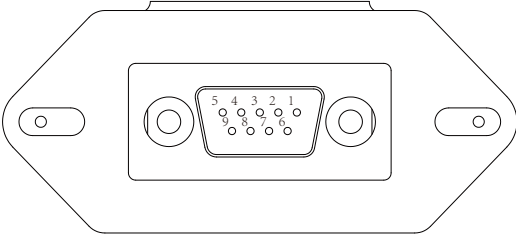

DB9 (RS232)

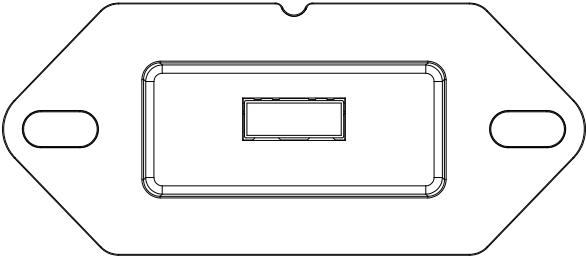

USB

11. Appendix II

1. Split Core Current Transformer (CT) dimension: (mm)
2. Secondary output cable length is 4m.

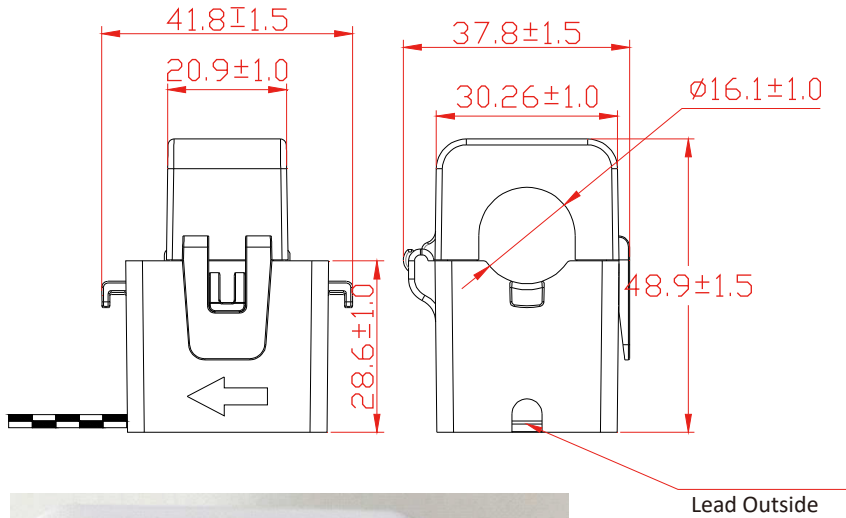



FESTON S.E.V PRIVATE LIMITED



Add.: 3rd Floor, No. 97/80, Vanagaram Service Road, Athipattu,
Ambattur, Chennai, Tamil Nadu, 600058, India

Tel.: +91 8925827701

E-mail: sales@festonsev.com

Web.: www.festonsev.com